

Noise Suppression by EMIFIL[®] Application Guide

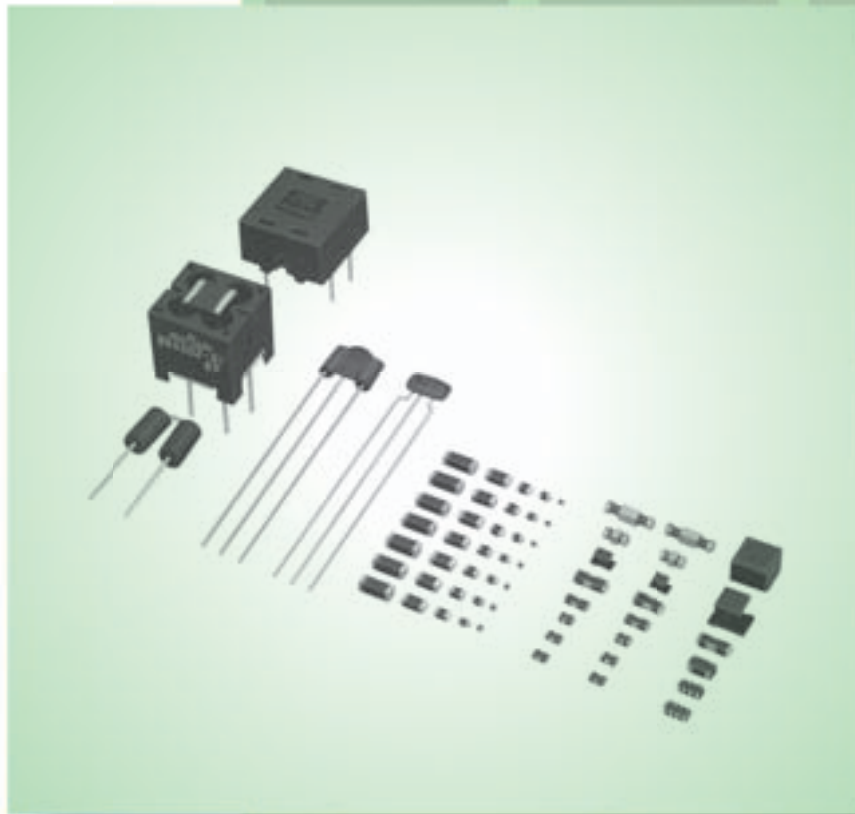

Application Manual

muRata *Innovator
in Electronics*
Murata
Manufacturing Co., Ltd.

Introduction

To make effective noise suppression in electronic equipment it is necessary for design engineers to have a good understanding of the various types of EMI suppression filters available and the characteristics so that they can use suitable components.

Because filtering characteristics of EMI suppression filters depend significantly on the construction, a wide variety of products are available in the market, it is difficult to understand all of them.

This brochure provides an overview of EMI suppression filters by classifying them into several groups and describing the characteristics of each group along with a brief summary for the engineers.

This publication is intended to help readers to make correct selection of EMI suppression filters for their applications.

Definition

DC EMI suppression filters : EMI filters to be used in the secondary side DC circuits such as digital circuits, audio and video circuits.

*EMIFIL® and EMIGUARD® are the registered trademarks of Murata Manufacturing Co., Ltd.

CONTENTS

1	Example of Noise Suppression in Desktop PCs —	2
	Noise Emission Status	2
	Noise Suppression Content in Personal Computers	3
	Improving Shielding	4
	Installing EMI filters on Interface Cable Ports	4
	Example of effects produced when improving the GND and installing EMI filters on the cable connector port..	5
	Improving the GND on Extension Boards	6
	Installing EMI filters on the Clock Lines.....	6
	Installing EMI filters on Bus Lines.....	6
2	Example of Noise Suppression in Notebook PCs —	7
	Noise Emission Status	7
	Noise Suppression Content in Notebook Personal Computers	8
	Improving the Case Shielding and GND Connection	9
	Improving the External Card GND	9
	EMI Filter at LVDS Cable Connection.....	9
	Noise Suppression in LCD	10
	Installing EMI filters on Interface Cable Ports	10
	Installing EMI Filters on the DC Power Supply Input.....	10
3	Example of Noise Suppression for USB's —	11
	Noise Suppression Content for USB	12
	Examples of transmission signal waveforms and noise suppressing effects in HS mode ..	13
4	Example of Noise Suppression in CD-ROM Drives —	14
	Noise Emission Status	14
	Noise Suppression Content in CD-ROM Drives	15
	Installing EMI Filters on the Headphone Output Port.....	16
	Installing EMI filters on the Clock Line	16
	Installing EMI filters on Bus Lines.....	16
	Example of effects produced when installing the Chip Ferrite Bead on the bus lines	17
	Installing EMI filters on Interface Cable Ports	18
5	Example of Noise Suppression in DVD Players —	19
	Noise Emission Status	19
	Noise Suppression Content in DVD Players	20
	Improving the Shielding	21
	Installing EMI filters on Interface Cable Ports	21
	Installing EMI filters on the Clock Line	21
	Installing EMI Filters on Bus Lines.....	22
	Installing EMI Filters on High-speed Bus Lines.....	22
6	Example of Noise Suppression in Printers —	23
	Noise Emission Status	23
	Noise Suppression Content in Printers	24
	Improving the GND	25
	Installing EMI filters on Motor Control Lines.....	25
	Installing EMI filters on the Parallel Interface	25
	Installing EMI filters on the DC Power Supply Input and Lines	25
	Installing EMI filters on the Clock Line	26
	Example of effects produced when installing EMI filters on the Clock lines ..	26
	Installing EMI filters on Bus Lines.....	27
7	Example of Noise Suppression in Fax Machines —	28
	Noise Emission Status	28
	Noise Suppression Content in Fax Machines	29
	Installing EMI filters on Interface Cable Ports	30
	Installing EMI filters on the DC Power Supply Input and Lines	30
	Installing EMI filters on Signal Lines to the Handset	30
	Installing EMI filters on the Clock Line	30
	Example of effects produced when installing EMI filters on the Clock lines ..	31
	Installing EMI filters on Bus Lines.....	31
8	Example of Noise Suppression for Car Navigators —	32
	Noise Emission Status	32
	Noise Suppression Content in Car Navigators	33
	Improving the Shielding	34
	Installing EMI filters on Interface Cable Ports	34
	Example of effects produced when installing EMI filters on Interface Cable Ports ..	35
	Installing EMI filters on the Clock Lines.....	36
	Installing EMI filters on Bus Lines.....	36
9	Example of Noise Suppression in AC Power Supplies —	37
	Noise Emission Status for Switching Power Supplies	37
	Noise Suppression Model for Ordinary Switching Power Supplies.....	38
	Differential Mode Noise and Common Mode Noise.....	39
	Functions of Respective Noise Filters	40
	Noise Tendencies in Switching Power Supplies.....	41
	Examples of Suppression against Strong Differential Mode Noise ..	42
	Reasons Why Common Mode Choke Coils Contain Mode Inductance.....	43
	Effective Suppression Methods against Differential Mode Noise using Hybrid Choke Coils ..	44
	Examples of Confirming the Effectiveness of Hybrid Choke Coils.....	45
10	Example of Noise Suppression in Mobile Phones —	46
	Noise Emission Status	46
	Noise Suppression content in Mobile Phones	47
	Installing EMI filters on LCD line.....	48
	Installing EMI filters on DC Power Supply	48
	Installing EMI filters on Data Line	48
	Installing EMI filters on interface section.....	49
	Improving the Shielding	49

1	Example of Noise Suppression in Desktop PCs
2	Example of Noise Suppression in Notebook PCs
3	Example of Noise Suppression for USB's
4	Example of Noise Suppression in CD-ROM Drives
5	Example of Noise Suppression in DVD Players
6	Example of Noise Suppression in Printers
7	Example of Noise Suppression in Fax Machines
8	Example of Noise Suppression for Car Navigators
9	Example of Noise Suppression in AC Power Supplies
10	Example of Noise Suppression in Mobile Phones

1 Example of Noise Suppression in Desktop PCs

Noise Emission Status :

Noise is emitted from the cables connected to a personal computer.

When using a computer case that does not have efficient shielding, radiated noise from the computer body may sometimes cause problems.

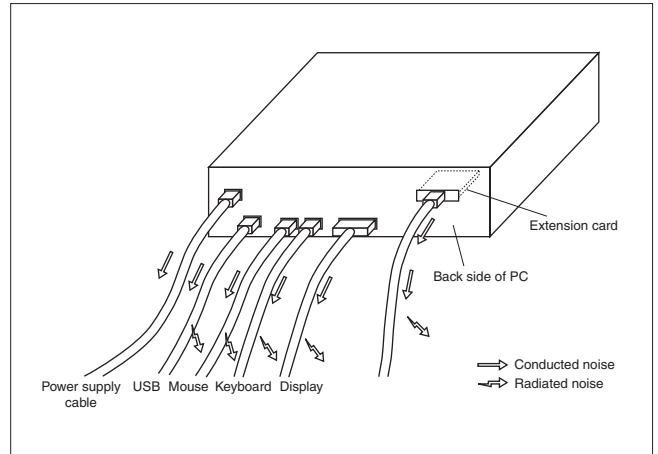

Example of Noise Suppression in Desktop PCs 1

Noise Suppression Content in Personal Computers

A PC contains many sources of noise inside and out, with many connected cables. Therefore, it is necessary to use EMI filters on the interface cables, in addition to shielding and improving GND connections. The PCB incorporates many signal lines that contain high-level noise. The EMI filters should also be mounted on potential noise sources such as the clock line, bus line and DC power supply line, to suppress noise conduction to the cable.

1

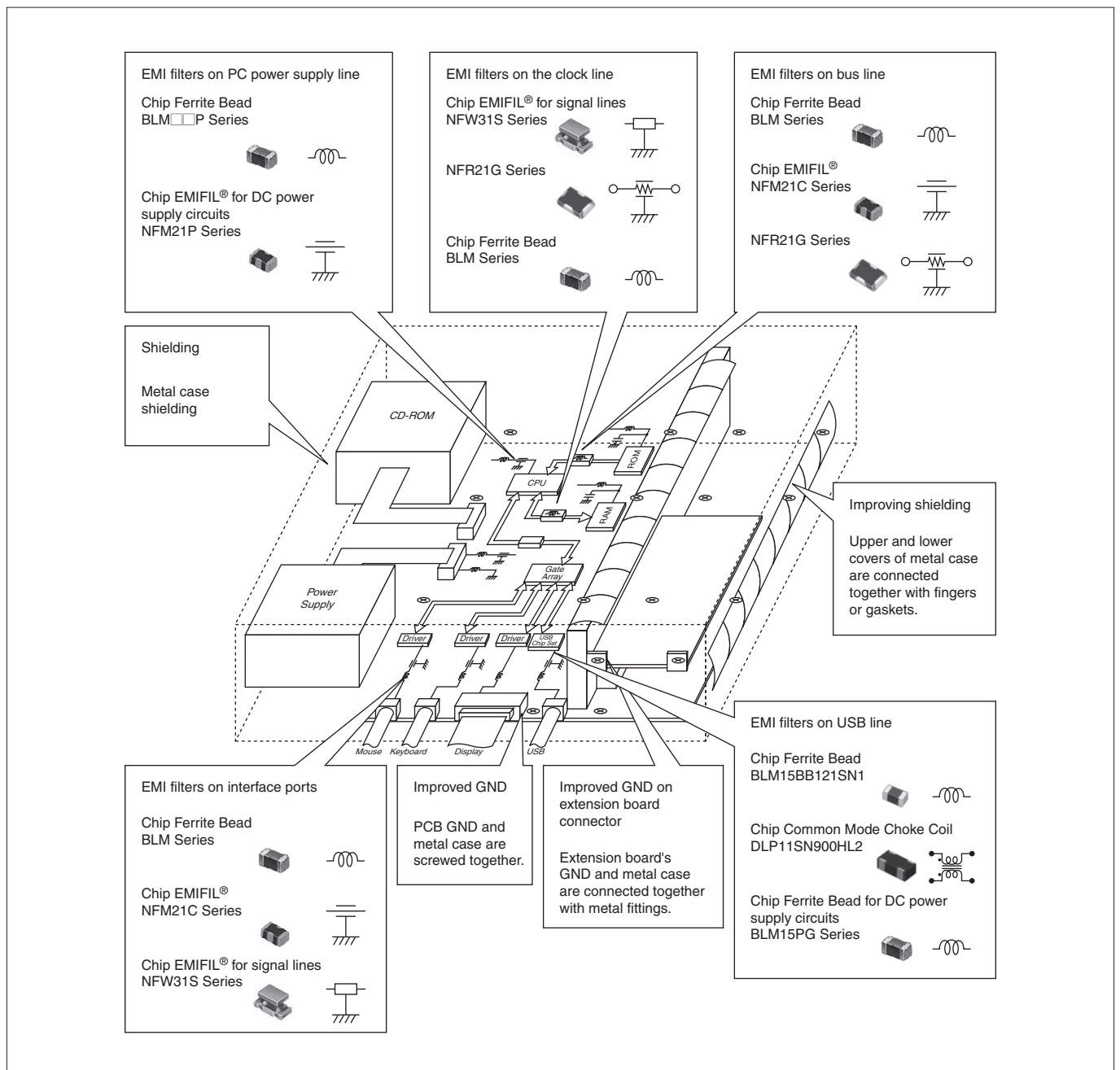

1 Example of Noise Suppression in Desktop PCs

Improving Shielding

Parts of the metal case make contact with each other by surface contact, where fingers and gaskets are used where necessary to minimize the impedance of contact points at high frequencies. Overlaps should be provided for each edge of upper and lower covers to eliminate any gaps between the covers.

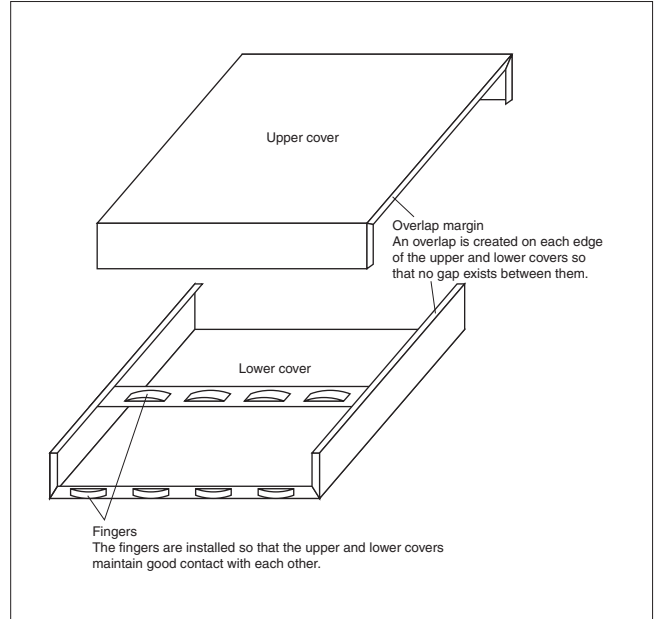

Installing EMI filters on Interface Cable Ports

On the interface cable connection, three terminal capacitor NFM21C series, and Chip Ferrite Bead BLM series are used together to achieve better noise suppression. In some cases, the EMIFIL® for signal lines is used. It is important to design the circuitry to minimize the high frequency impedance between the EMI filter's GND (of circuit board) and the metal case.

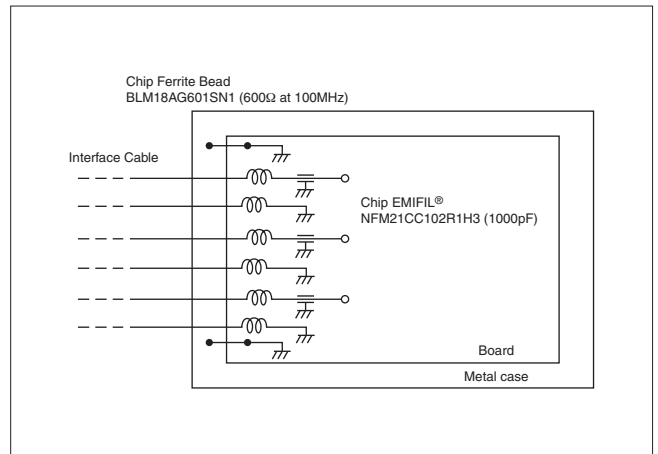

1

Example of Noise Suppression in Desktop PCs 1

Example of effects produced when improving the GND and installing EMI filters on the cable connector port

In the data above the GND is improved by increasing the number of connection points between the board and chassis, and then an EMI filter, NFM21CC222R1H3 is installed on the cable. This suppresses the noise level by 10dB.

1

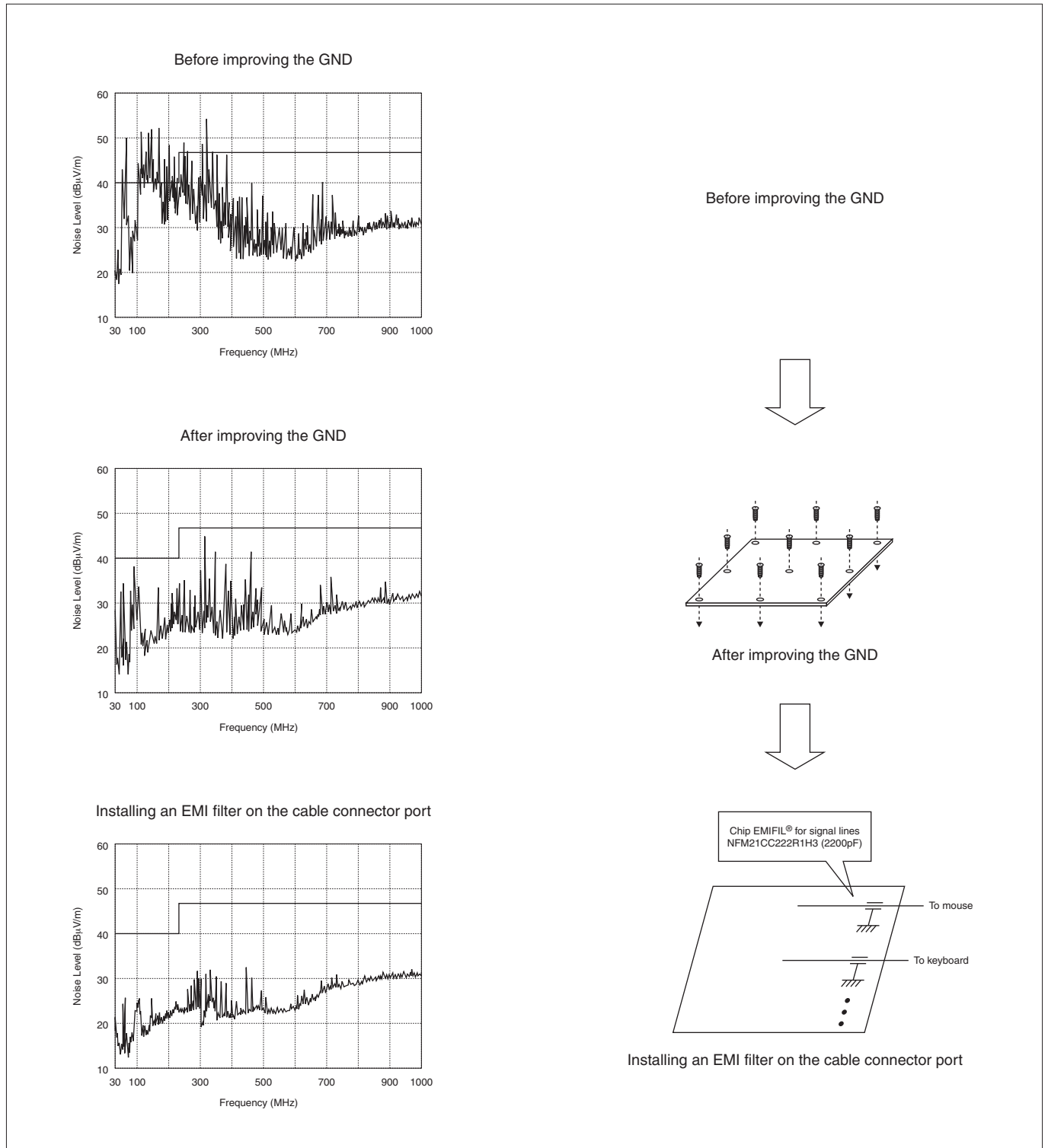

1 Example of Noise Suppression in Desktop PCs

Improving the GND on Extension Boards

In case of installing an extension board with a cable, noise may conduct to the cable when GND noise level is high. This results in high-level noise radiation from the cable. Therefore, the board's GND must be stabilized by connecting the GND with the metal fitting (which is connected to the metal case of the personal computer) with screws so that high frequency impedance is low. In addition, EMI filters are installed on the cable connector port.

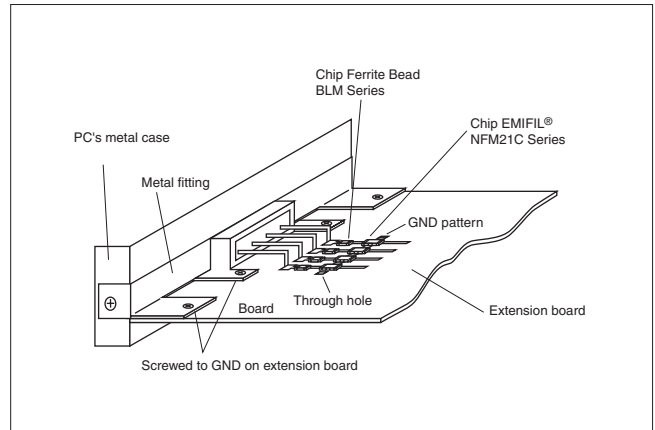

Installing EMI filters on the Clock Lines

High frequency clock signals generate high frequency noise. Noise and signal frequencies may be close to each other. Therefore, an EMI filter with high and steep attenuation is used such as the NFW31S series (Chip EMIFIL® for signal lines), or the BLM□□B series (Chip Ferrite Bead for high-speed signal lines).

Noise caused by transient currents is also generated on the power supply line. Therefore, a chip ferrite bead is installed, as well as a by-pass capacitor, to suppress noise on the power supply line.

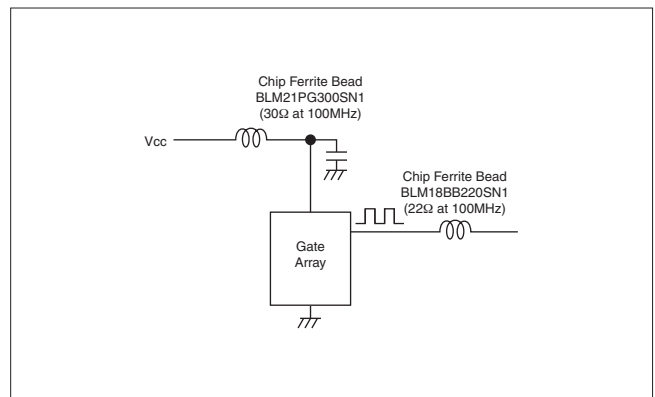

Installing EMI filters on Bus Lines

Bus lines contain many lines that switch on and off simultaneously. Especially on data and address bus lines, an instantaneous large current flows into the GND and power supply lines. Therefore, it is necessary to suppress the current flow on the signal lines. The BLM series (Chip Ferrite Bead) is generally used for this purpose.

On the control bus line, especially at high operating speeds and high noise levels, a filter with resistance components is used, such as the NFR21G series (Chip EMIFIL®).

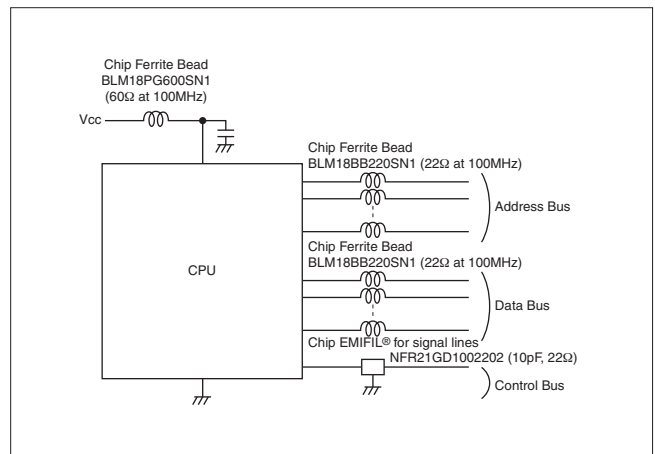

1

2 Example of Noise Suppression in Notebook PCs

Noise Emission Status :

Noise emission from PC body, LCD, connection cables, and connection cable between PC body and LCD.

In notebook PCs, PCBs incorporate many signal lines with high-level noise. Generally, notebook PCs use a resin case with conductive plating, which provides a lower shielding effect than the metal case of desktop PCs, causing high level noise to be emitted from the PC body. Furthermore, they use many connection cables,

which also emit noise.

In most cases, transmission signals to the LCD are LVDSs (Low Voltage Differential Signals). Since the LVDSs are high-speed signals containing high level noise, the connection cable between the PC body and LCD also emits high level noise.

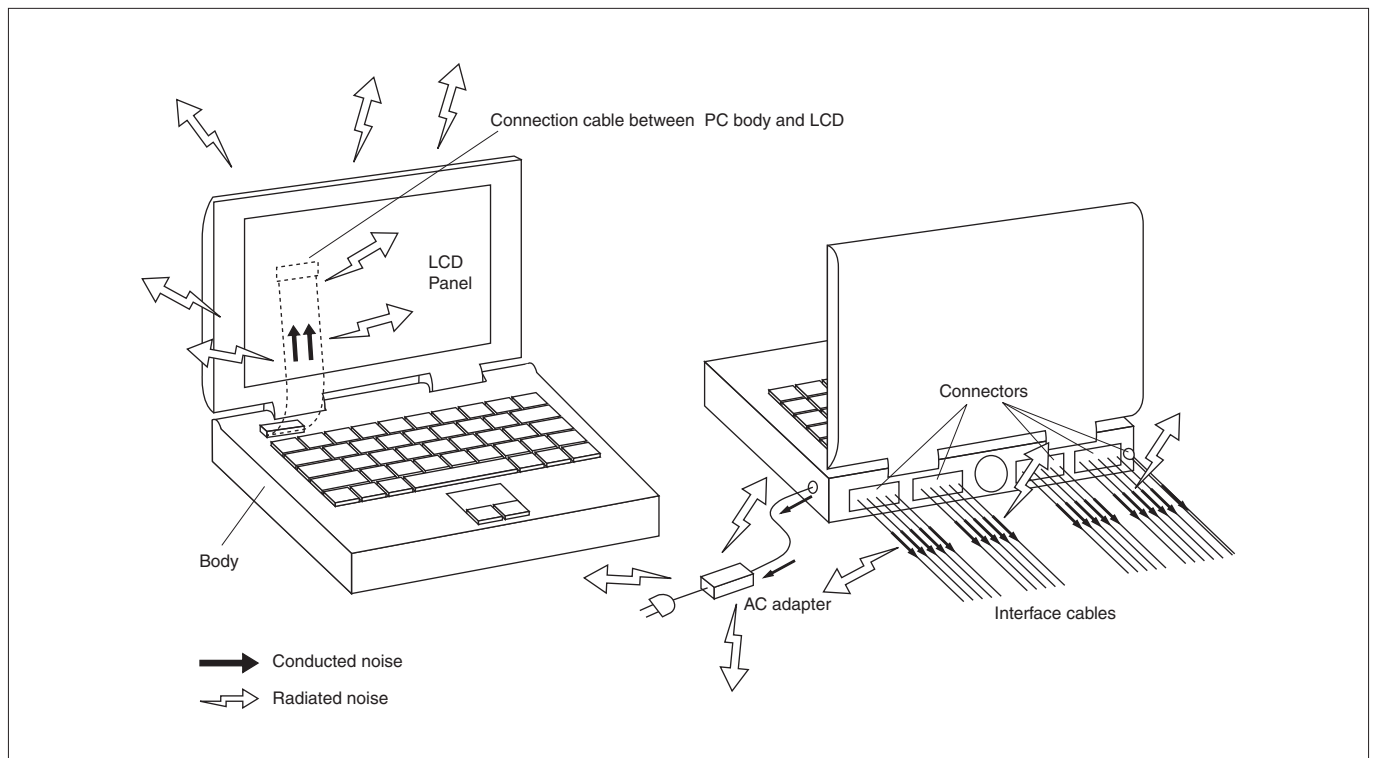

2 Example of Noise Suppression in Notebook PCs

Noise Suppression Content in Notebook Personal Computers

Notebook PC components are mounted in a limited space. Therefore, it is important to intensify the shielding condition as much as possible to suppress noise emission, before mounting noise-suppressing components. As shielding measures, the resin case is provided with conductive plating, and metal plates are provided above and below the PCB to intensify the shielding condition. For cable connectors, the PCB GND is connected with the metal plates to intensify the GND condition, and additionally, noise suppressing components are mounted.

Transmission signals to the LCD are mainly LVDSs (Low Voltage Differential Signals), which also emit

high-level noise.

Therefore, the DLP series common mode choke coils should be mounted to the signal lines. In some cases, it is also necessary to shield the cables. The LCD incorporates many signal lines that are connected from the graphic control IC to the LCD driver. Because these signal lines may emit noise, chip ferrite beads (e.g. BLM series) should be mounted to the signal lines to suppress noise emission.

The card slot for connecting an external card, such as PCMCIA card, must be designed to reduce the high frequency impedance between the PCB GND and the card. Also, the card slot must be shielded.

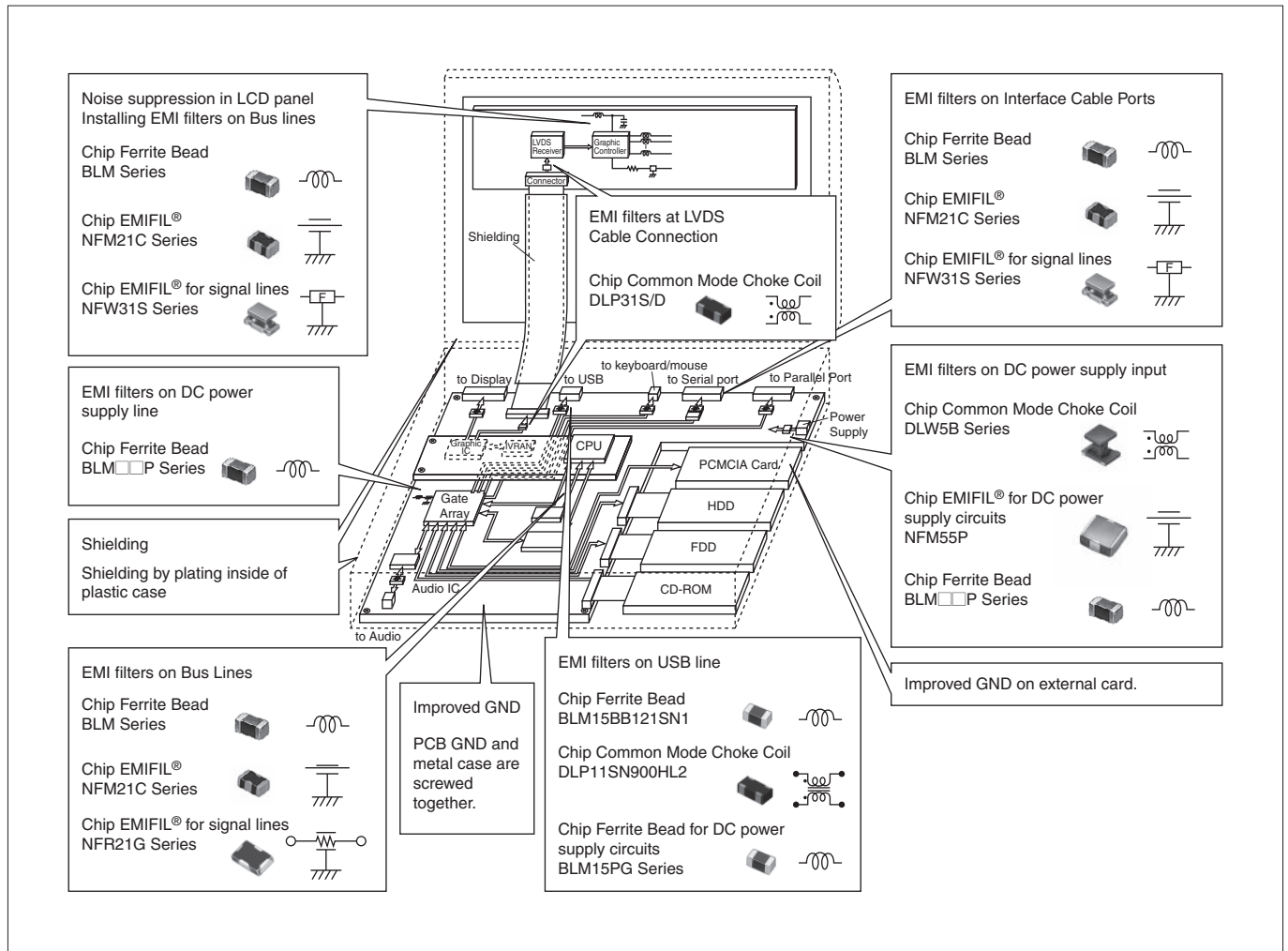

Example of Noise Suppression in Notebook PCs **2**

Improving the Case Shielding and GND Connection

Since plastic is usually used to encase a notebook PC, conductive plating is applied to the inside of the case. However, conductive plating alone is not sufficient for shielding. Therefore, to improve the GND, metal plates are also installed above and below the PCB. These plates are screwed together so they maintain contact with the PCB's GND and the conductive plating.

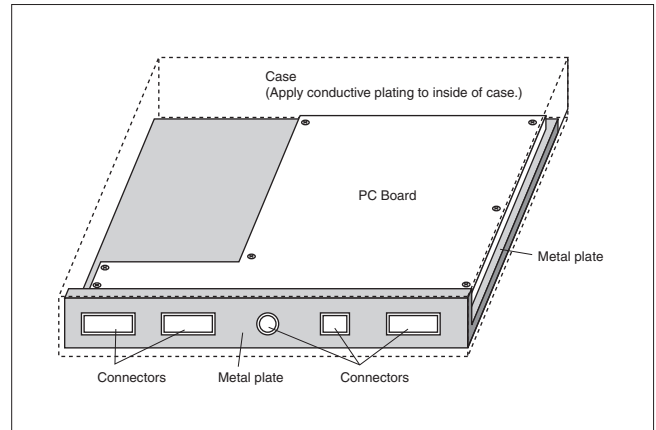

Improving the External Card GND

When an external card with a cable is connected, noise is emitted not only from the card itself but also from the notebook PC, conducted through the cable. When the high frequency impedance between the card's GND and PC's GND is high, the card's GND becomes unstable. This makes noise suppression difficult. Therefore, the slot fingers in contact with the card's GND are screwed to the PCB's GND and metal plate, minimizing the high frequency impedance between them. If the PC's noise affects the card, radiated noise cannot be suppressed, even if the card contains a noise suppressor. In this case, the slot is shielded with a metal plate.

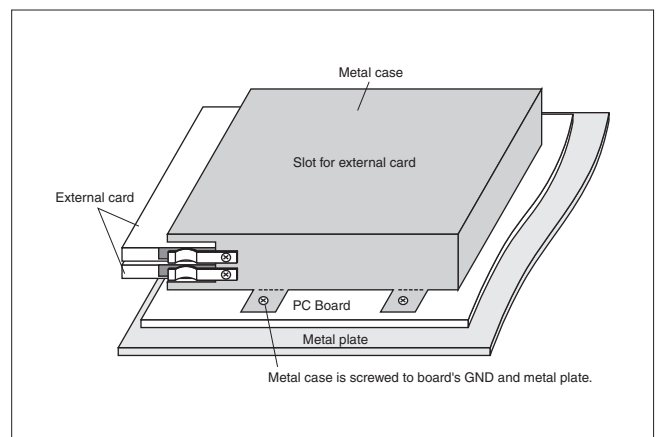

When the ground connection relies on physical contact, such as when an external card makes contact with the slot, the level of radiated noise varies widely depending on the status of the contact. When taking measures to suppress noise or measure the noise level, care must be taken.

EMI Filter at LVDS Cable Connection

The connection cable between the PC body and LCD raises problems on noise emission due to signal harmonics to the LCD, and from the surrounding circuits other than the signal line.

Because LVDSs (Low Voltage Differential Signals) are transmitted at a high-speed of several hundred MHz, common mode choke coils should be used to prevent rounding of the signal waveform. LVDSs are based on the differential transmission method, which cancels magnetic flux generated by a current, resulting in noise suppression. However, the current may be unbalanced by signal reflection. In this case, the common mode choke coil serves as a transformer to balance the current, thus enabling the noise caused by the unbalanced current to be suppressed.

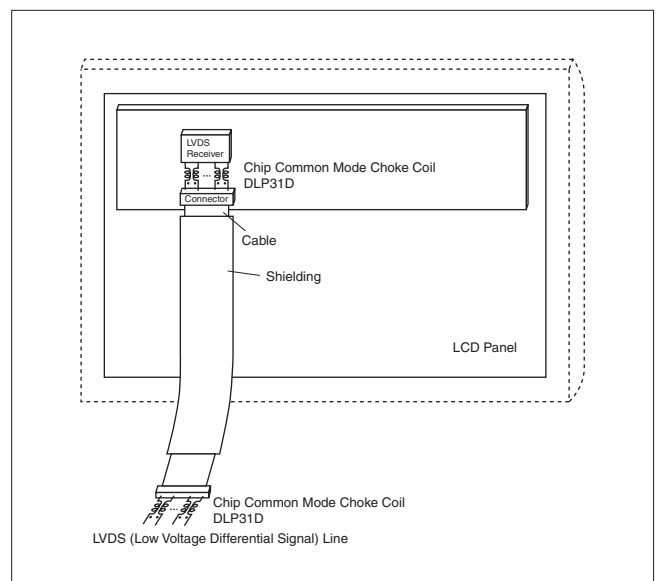

2 Example of Noise Suppression in Notebook PCs

Noise Suppression in LCD

The connection between the graphic controller and LCD driver contains many lines that switch on and off simultaneously. This switching creates instantaneous large current flows into the GND and power supply line. Therefore, it is necessary to suppress the current flow from the signal lines. The BLM series (Chip Ferrite Bead) is typically used for this purpose. On the clock line, especially at high operating speeds and high noise levels, a filter with high and steep attenuation is used, such as the NFW31S series (Chip EMIFIL® for signal lines).

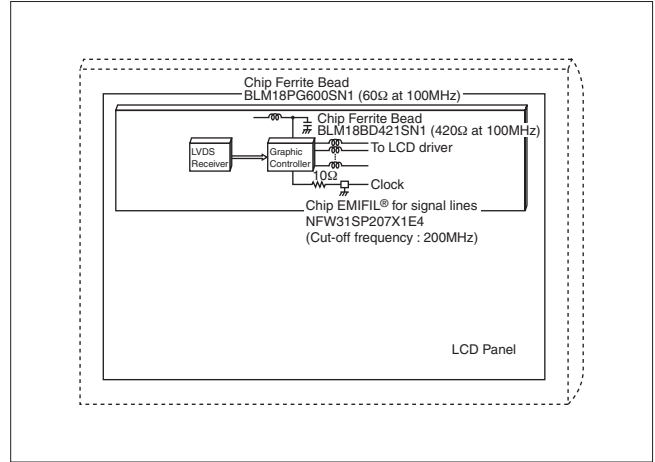

Installing EMI filters on Interface Cable Ports

On the lines to the interface cable, three terminal capacitor the NFM21C series and Chip Ferrite Bead BLM series are generally installed in combination. In some cases, the EMIFIL® for signal lines is used. It is important to design the circuitry to minimize the high frequency impedance between the EMI filter's GND and the metal plate.

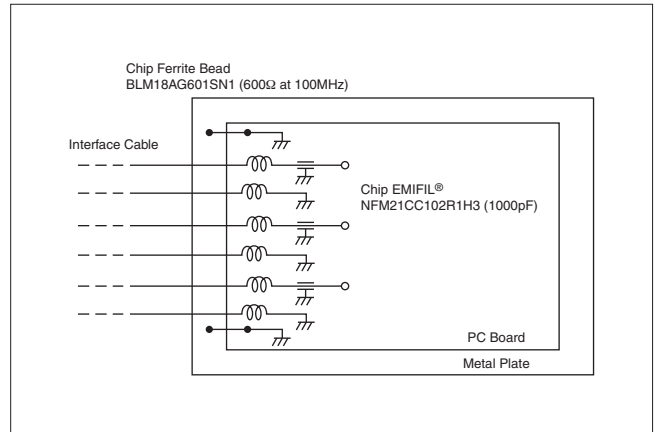

Installing EMI Filters on the DC Power Supply Input

Since noise is radiated from the DC power supply cable of the AC adapter, some noise suppression is necessary at input to DC power supply of personal computer. The DC power supply line contains both differential mode noise and common mode noise. Both mode noises need to be suppressed.

The GND and metal plate are first connected together. The NFM55P series (Chip EMIFIL®) and the BLM□□P series (Chip Ferrite Bead) are used for differential mode noise suppression. The DLW5BS/AH series (Chip Common Mode Choke Coil) is used for common mode noise suppression.

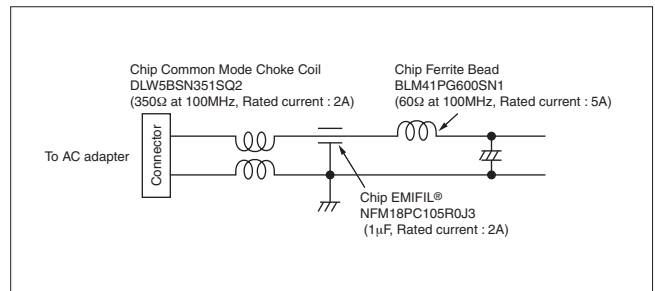

3 Example of Noise Suppression for USB's

The USB (Universal Serial Bus) was devised as an external bus to connect a PC (host) and its peripherals (functions).

Because of easiness to use, the USB is expected to rapidly become widespread in the future.

The major noise problem with USB's is noise radiation from the cables. However, common mode noise from other circuits does tend to be stronger than generated by USB signal because USB used differential data transmission.

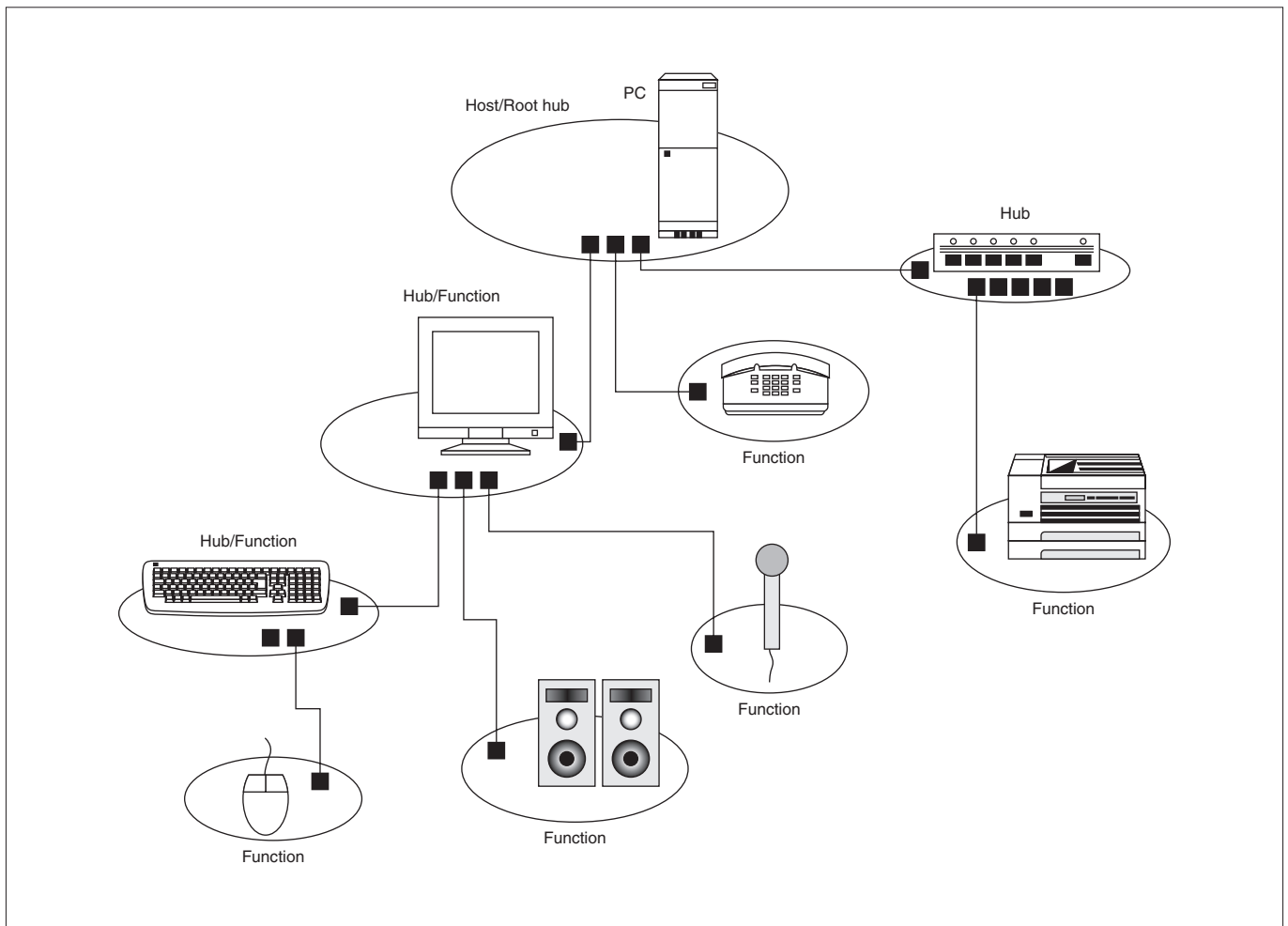

3

3 Example of Noise Suppression for USB's

Noise Suppression Content for USB

USB's support three types of transmission modes, depending on the function of the connected device: LS (Low Speed: 1.5Mbps), FS (Full Speed: 12Mbps) and HS (High Speed: 480Mbps). In order to suppress noise emission without deforming the signal waveform, it is necessary to take noise suppressing measures suitable for individual transmission modes.

For noise suppression in the LS/FS mode, chip ferrite bead BLM18BB121SN1 or common mode choke coil DLP11SN900HL2 should be mounted on the signal line, and the BLM□□PG series chip ferrite bead should be

mounted on the power supply and GND lines.

In the LS/FS mode, using the EMI filters raises the problem of signal waveform deformation. In this case, influence of the EMI filters on EOP (End of Packet) signal must also be watched.

In the high speed transmission mode such as the HS mode, using the ferrite bead results in signal waveform deformation. To prevent this problem, common mode choke coil DLW21SN900SQ2 should be used, instead of the ferrite bead to suppress noise emission.

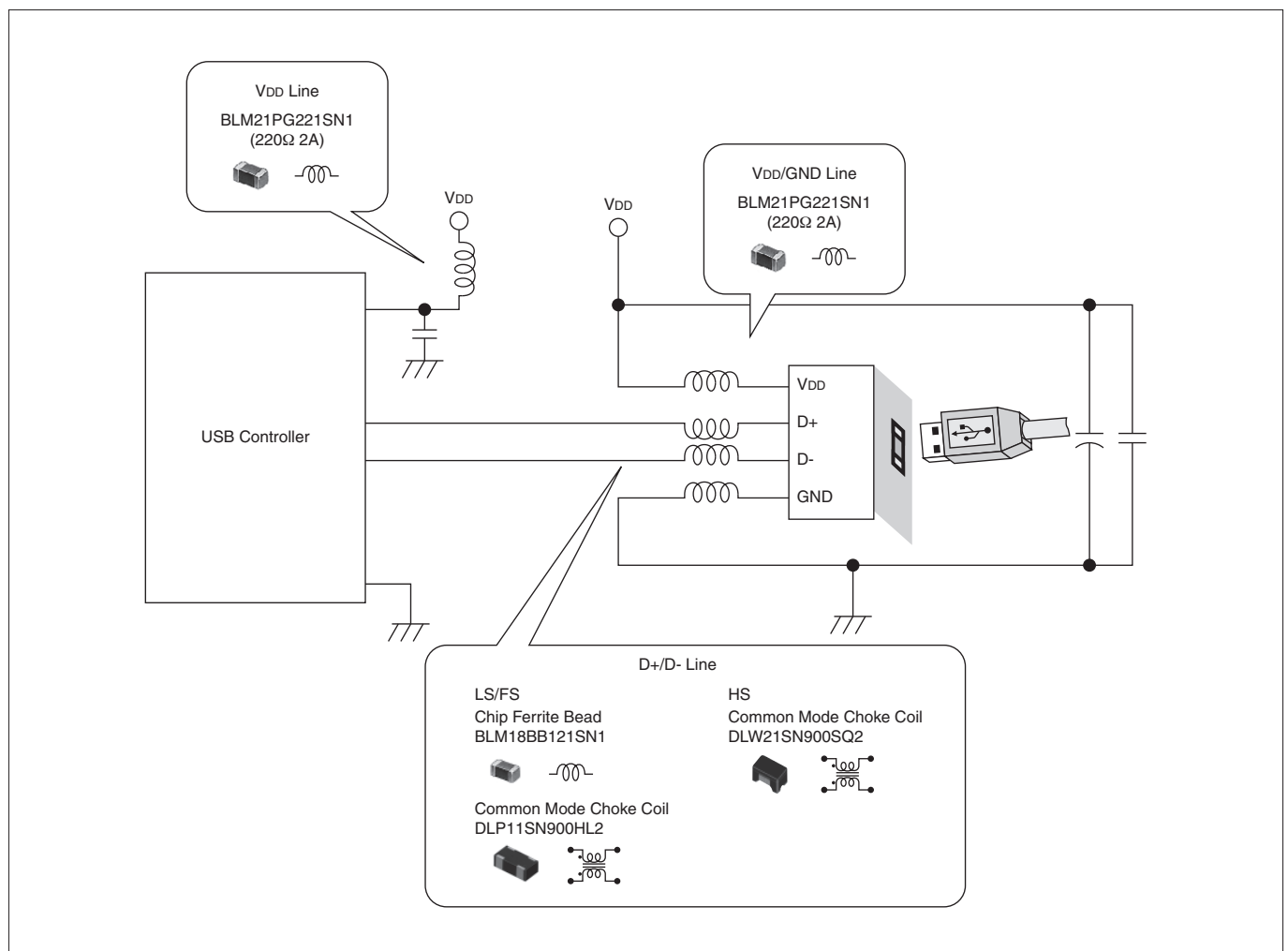

Example of Noise Suppression for USB's 3

Examples of transmission signal waveforms and noise suppressing effects in HS mode

An example of noise suppressing measures for the HS mode is described here.

For the HS mode, quality of the signal waveform is checked with eye patterns.

Common mode choke coil DLW21SN900SQ2 has little influence on the eye patterns. With the choke coil, noise emission can be reduced by approx. 5dB max.

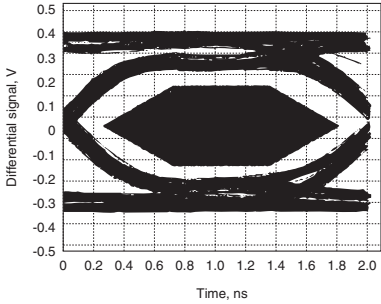
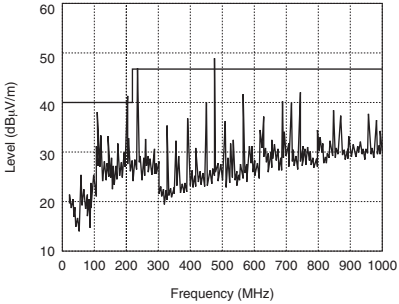
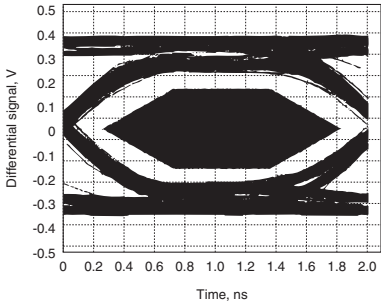
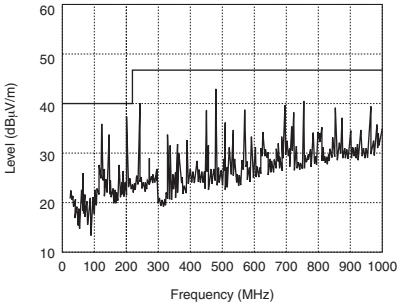
	Eye pattern	Level Noise
No Filter		
Common Mode Choke Coil DLW21SN900SQ2		

4 Example of Noise Suppression in CD-ROM Drives

Noise Emission Status :

Noise from both the CD-ROM drive and computer are conducted through the headphone cable and radiated.

Since an internal CD-ROM drive is shielded with a metal case, radiated noise from the CD-ROM drive rarely causes a problem. However, in some cases, radiated noise from the headphone cable can cause problems.

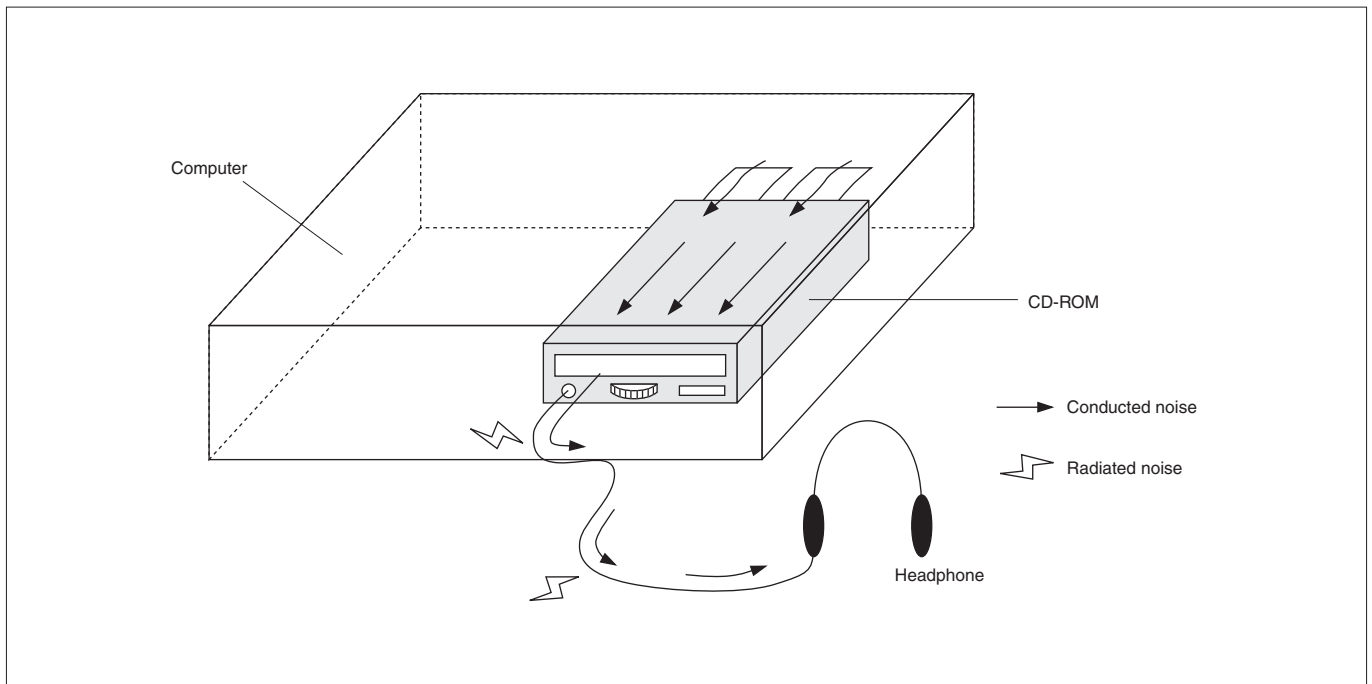

Example of Noise Suppression in CD-ROM Drives 4

Noise Suppression Content in CD-ROM Drives

Noise conducted to the headphone cable comes from the both the CD-ROM drive and the PC.

Initially, noise from the headphone cable needs to be suppressed. The PCB's GND is first connected to the metal case, and then EMI filters are installed. If radiated noise cannot be suppressed using these methods, additional measures must be taken. If the problem appears to be noise generated from the CD-ROM drive, the source of the noise must be suppressed. The first potential noise sources are the clock and bus lines.

Note that noise generated around the oscillator frequently can also cause problems. When noise generated around the D-A converter causes a problem, the point where the analog and digital GNDs are connected must be carefully considered. In many cases, improving this connection often suppresses the noise. If noise generated from the PC is causing a problem, EMI filters need to be installed on the cable between the PC and CD-ROM drive. Note that the CD-ROM drive may not operate on some computers if large capacitance or large inductance EMI filters are used.

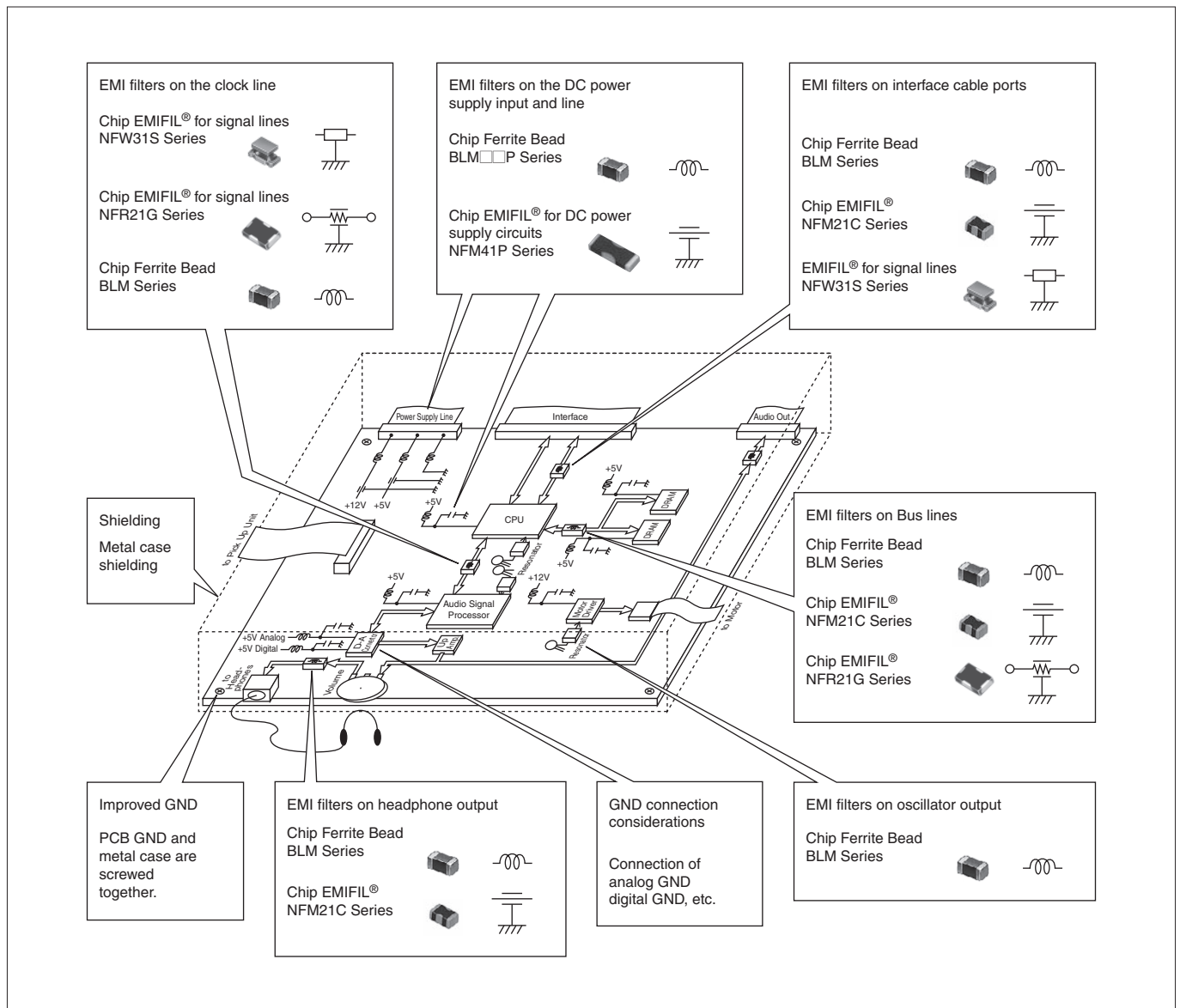

4 Example of Noise Suppression in CD-ROM Drives

Installing EMI Filters on the Headphone Output Port

To suppress noise in the headphone output port, it is important to minimize the GND's noise level of the port. The PCB's GND and metal case are screwed together to make a low impedance connection at high frequency. The NFM21C series (Chip EMIFIL[®]) capacitor is then installed on the headphone lines. More effective noise suppression can be achieved by also installing BLM series (Chip Ferrite Bead) on the lines.

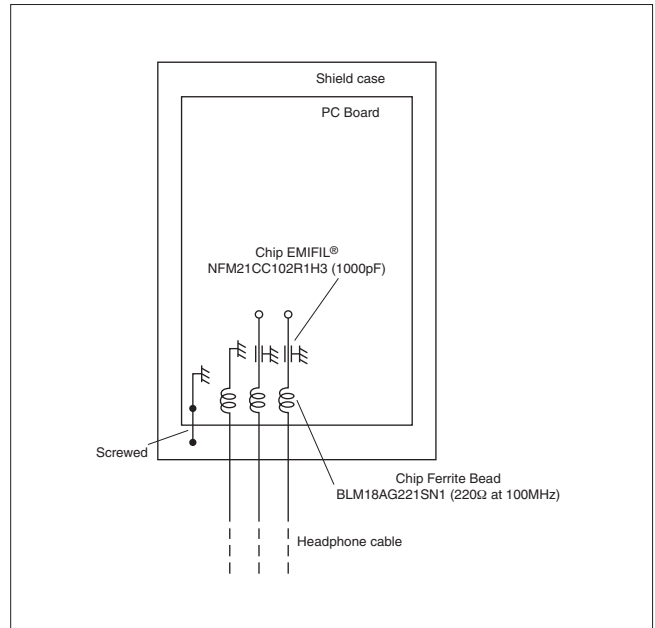

4

Installing EMI filters on the Clock Line

High-speed clock signals generate high frequency noise and in these conditions, the noise frequency may be sometimes quite close to the signal frequency. Therefore, an EMI filter with high suppression ability and steep attenuation characteristics is used such as the NFW31S series (Chip EMIFIL[®] for signal lines), or the BLM□□B series (Chip Ferrite Bead for high speed signal lines). Noise caused by transient current is also generated on the power supply line. Therefore, a chip ferrite bead is installed, as well as a by-pass capacitor to suppress the noise on the power supply line.

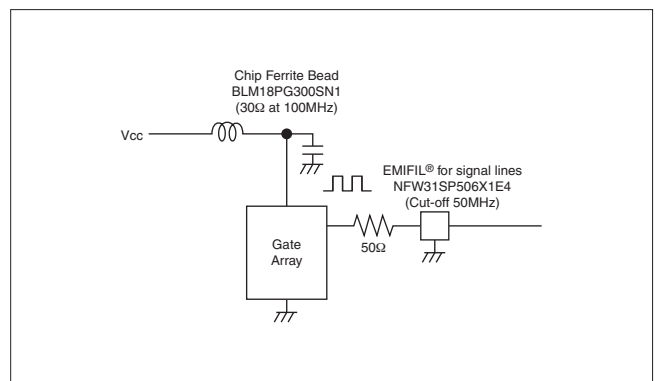

Installing EMI filters on Bus Lines

Data bus/Address bus lines contain many lines that switch on and off simultaneously. An instantaneous large current flows into the GND and power supply lines. Therefore, it is necessary to suppress the current flow to the signal lines. The BLM series (Chip Ferrite Bead) is generally used for this purpose. On the control bus line, especially at high operating speeds and high noise levels, a filter with resistance components is used such as the NFR21G series (Chip EMIFIL[®]).

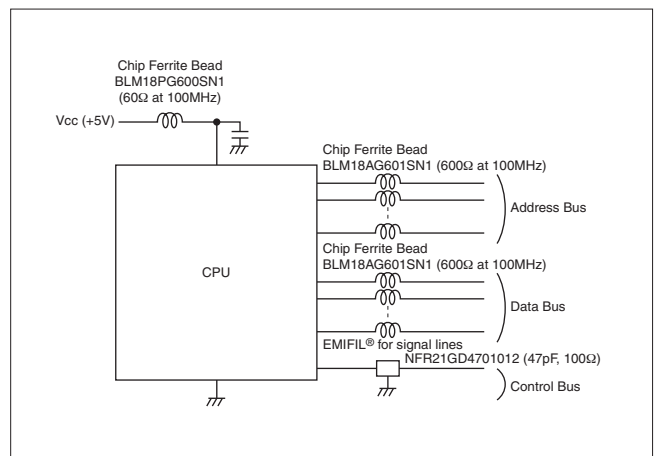

Example of Noise Suppression in CD-ROM Drives **4**

Example of effects produced when installing the Chip Ferrite Bead on the bus lines

Noise suppression effects produced when installing the BLM series on the data bus lines.

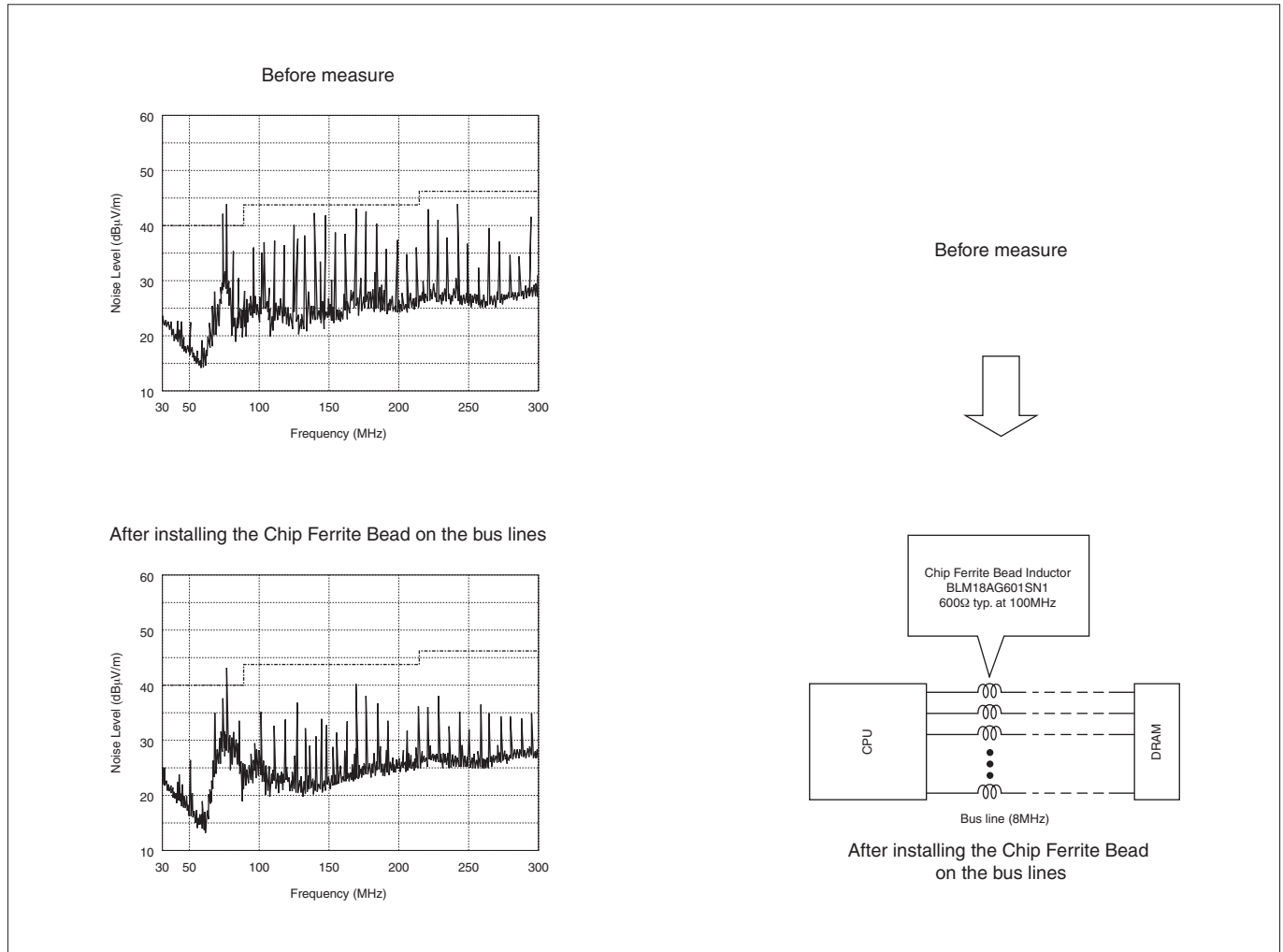

4 Example of Noise Suppression in CD-ROM Drives

Installing EMI filters on Interface Cable Ports

Minimizing the GND's noise level of PCB is important in the interface cable port. The PCB's GND and metal case are screwed together to form a low impedance connection at high frequency.

EMI filters are installed in the interface cable connection. Note that the CD-ROM drive may not operate on some computers if large capacitance or large inductance EMI filters are used.

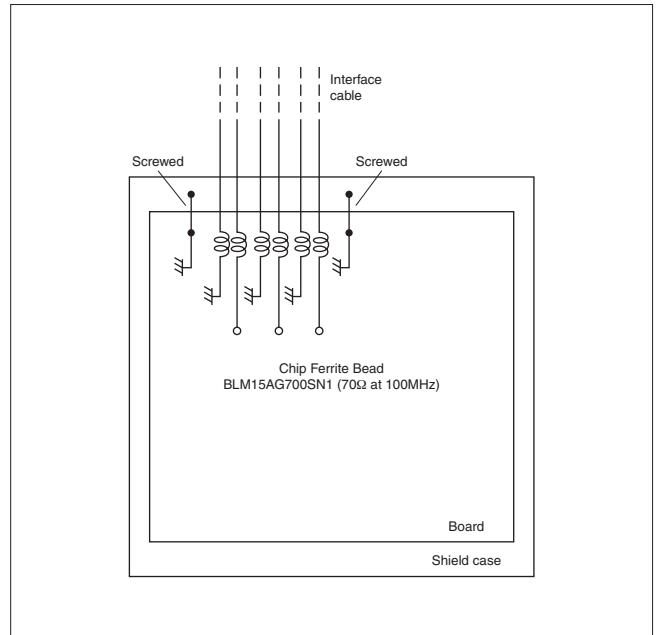

5 Example of Noise Suppression in DVD Players

Noise Emission Status :

Noise generated in the DVD player is radiated from the audio and video signal cables. In addition, although the player body is shielded with a metal case, radiated noise is emitted from the connector port openings.

A DVD player processes image signals using the MPEG2 method. Since image Processing requires high-speed signal processing, signals are transmitted at a very high speed. Therefore, high frequency noise around 1GHz, may be radiated.

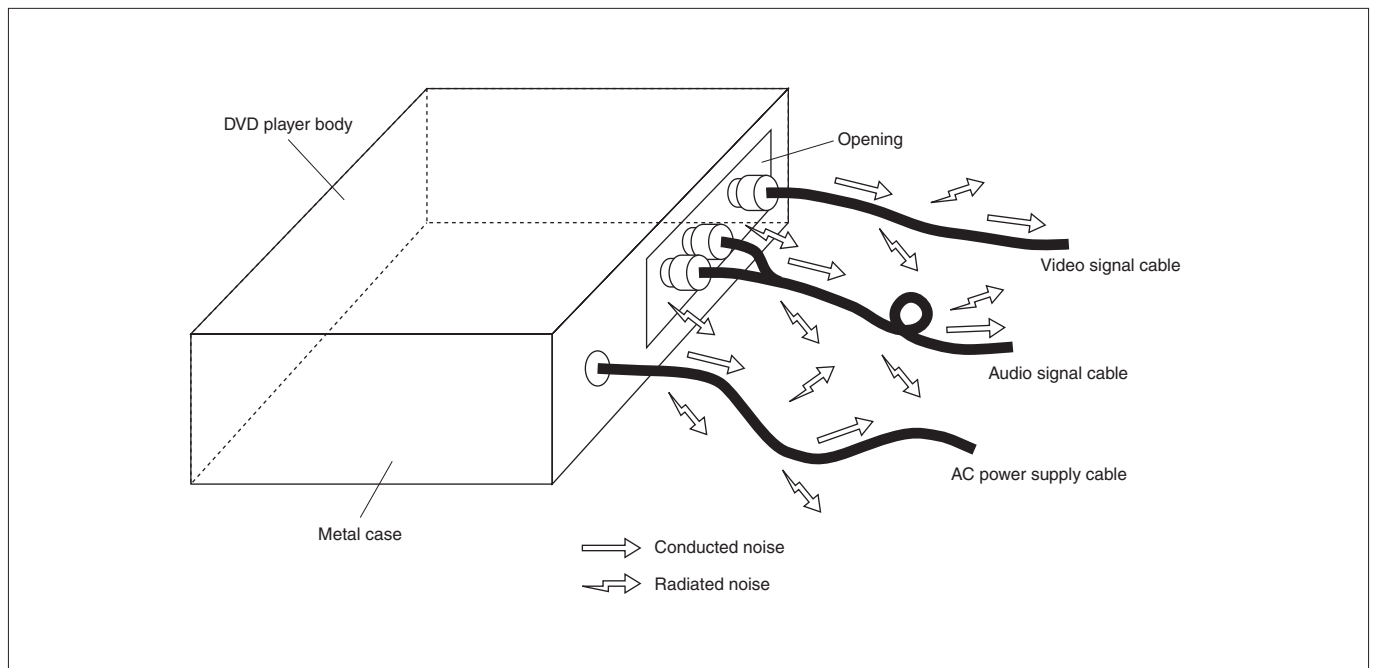

5 Example of Noise Suppression in DVD Players

Noise Suppression Content in DVD Players

High frequency noise radiates from the player body and cables. Therefore, the noise is suppressed by shielding the body and by installing noise filters in the cable port. However, it is necessary to carefully select noise filters because images or sounds could be deteriorated. If a high capacitance or high inductance filter is installed in the video or audio signal cable connection. In case that noise suppression in the cable

port is not enough, it is necessary to make noise suppression of the PCB by improving the GND, and by installing noise filters at noise sources. The high-speed data bus between the MPEG2 and SDRAM chips generates especially high-level noise. This noise can be suppressed by installing a BLM series (Chip Ferrite Bead) applicable for high-speed signal lines.

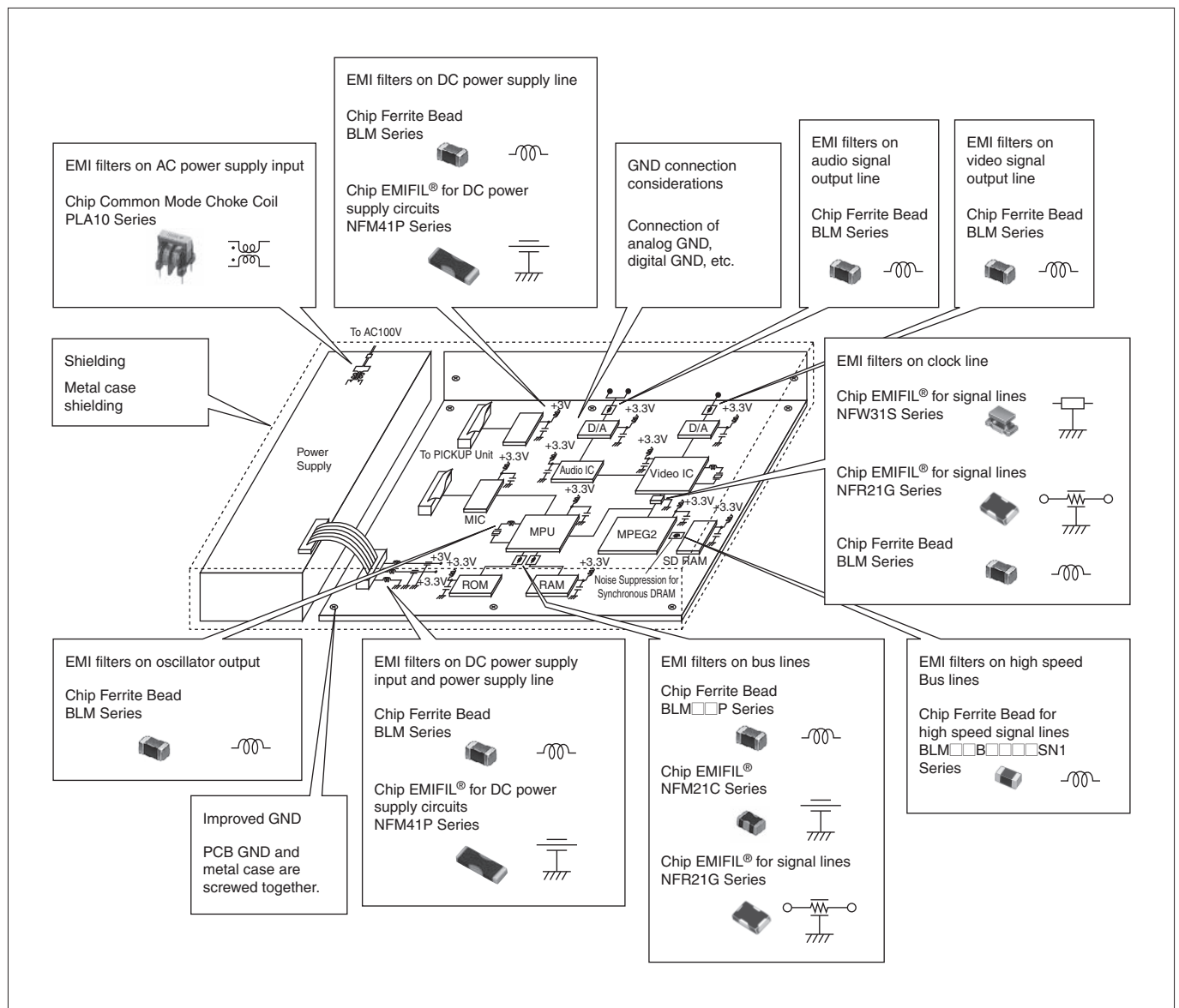

Example of Noise Suppression in DVD Players 5

Improving the Shielding

The size of the opening in the metal case affects the shielding effects. As the opening becomes larger, the shielding effect decreases. It is best if larger openings are divided into multiple smaller openings, making each opening as small as possible, with the objective of making the longest part of the opening as small as possible.

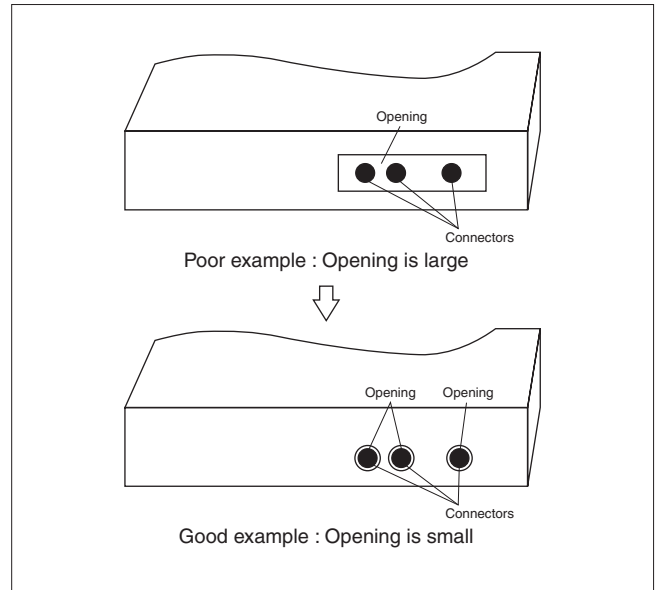

Installing EMI filters on Interface Cable Ports

When noise is conducted to the cable, the cable will radiate high noise levels. To suppress this noise, EMI filters are installed at the cable connection.

In some cases, the installed EMI filters may affect or deteriorate images or sounds. It is necessary to pay careful attention in selecting noise filters.

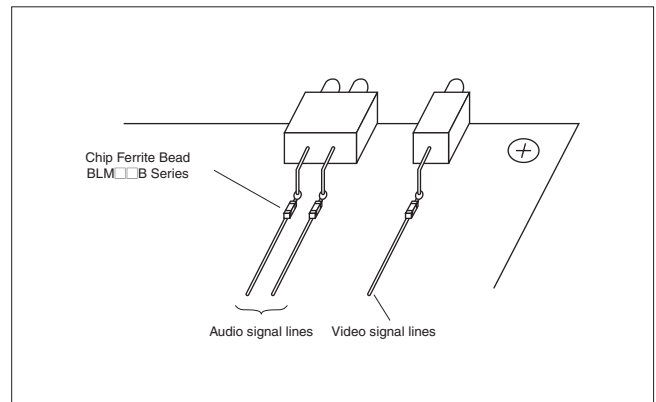

Installing EMI filters on the Clock Line

High frequency clock signals generate high frequency noise. Noise and signal frequencies may be close to each other. Therefore, an EMI filter with high and steep attenuation is used such as the NFW31S series (Chip EMIFIL® for signal lines), or the BLM□□B series (Chip Ferrite Bead for high-speed signal lines).

Noise caused by transient currents is also generated on the power supply line. Therefore, a chip ferrite bead is installed, as well as a by-pass capacitor, to suppress noise on the power supply line.

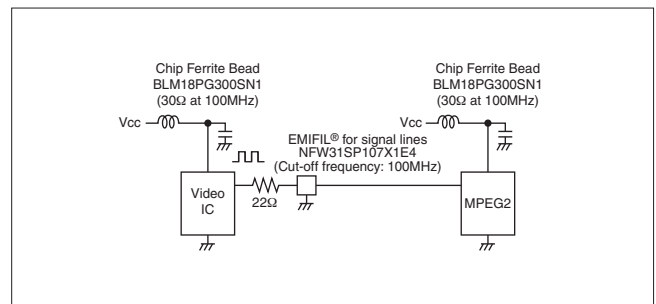

5 Example of Noise Suppression in DVD Players

Installing EMI Filters on Bus Lines

Data bus/Address bus lines contain many lines that switch on and off simultaneously. An instantaneous large current flows into the GND and power supply lines. Therefore, it is necessary to suppress the current flow to the signal lines. The BLM series (Chip Ferrite Bead) is generally used for this purpose. On the control bus line, especially at high operating speeds and high noise levels, a filter with resistance components is used such as the NFR21G series (Chip EMIFIL®).

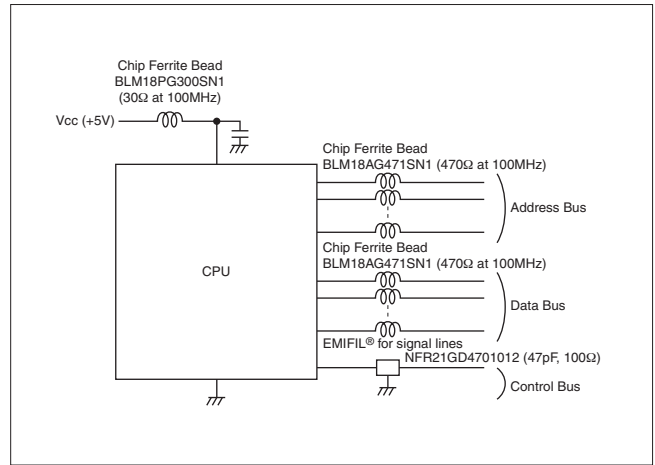

Installing EMI Filters on High-speed Bus Lines

Since very high speed signals are transmitted on the bus lines between the MPEG2 and SDRAM chips, high levels of high frequency noise are generated.

In these cases, the BLM□□BB□□□SN1 series (Chip Ferrite Bead for high-speed signal lines) is used.

Featuring a sharp impedance rise at the specified frequency, this filter is used to minimize distortion of the signal waveform.

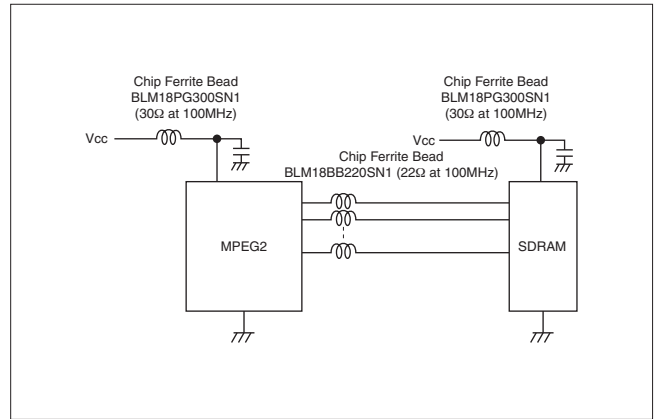

5

6 Example of Noise Suppression in Printers

Noise Emission Status :

Noise generated from the main printer board and from the drive motor are radiated from the printer cable.

In printers, noise generated from the main board is conducted to the printer cable and AC power supply cable, where they act as antennas. Noise generated while the motor is operating may sometimes cause a problem. In addition, friction between paper sheets generates static electricity, causing a malfunction.

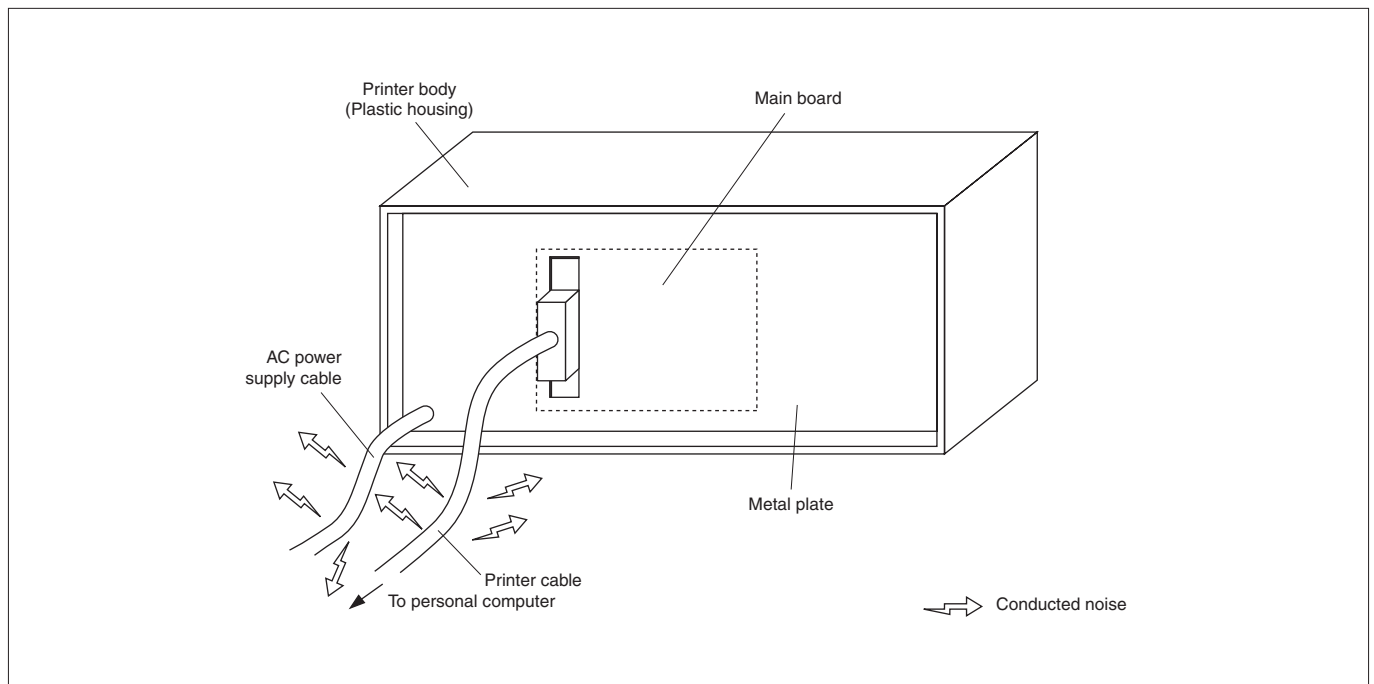

6 Example of Noise Suppression in Printers

Noise Suppression Content in Printers

In printers, the GND is improved to suppress noise from the main board and prevent static electricity from causing a malfunction. A GND plate (metal plate) is installed onto the rear face of the main board and connected to the main board GND.

To suppress noise conduction from the main board to the printer cable, EMI filters are installed on the printer cable port (parallel interface). To suppress noise

conduction to the AC power supply cable, EMI filters are installed on the DC power supply input and DC power supply line. To suppress noise caused by the motor, EMI filters are installed on the motor control signal lines. When noise radiated from the board itself is combined with noise from the surrounding cables, ferrite beads are installed on the clock and bus lines.

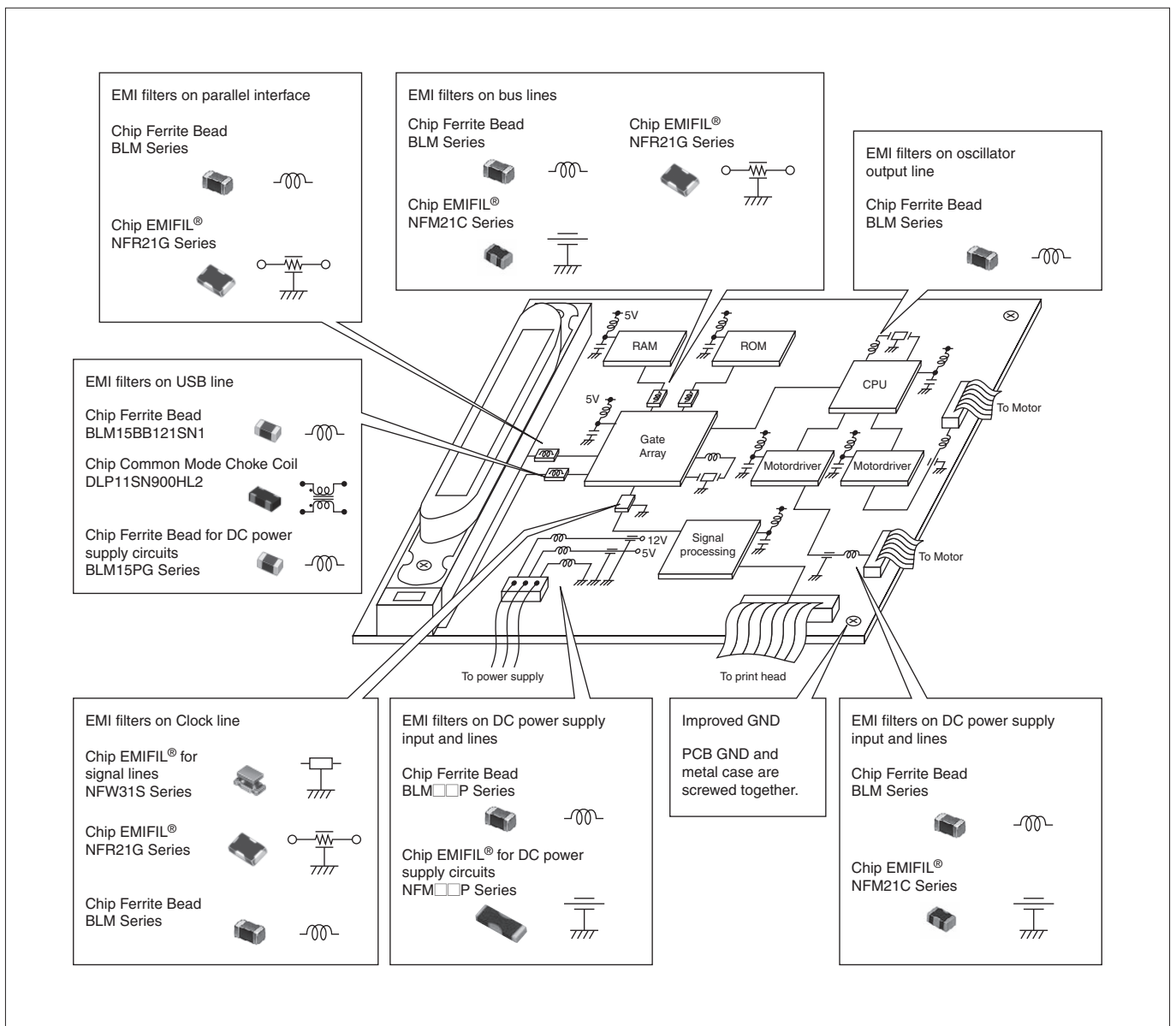

Example of Noise Suppression in Printers 6

Improving the GND

To reduce the level of noise from the main board, a GND plate (metal plate) is installed onto the rear face of the main board to improve the GND. The main board GND and GND plate are connected at several points. However, if the connection points are inappropriate, the noise level may increase. Therefore, great care must be given when selecting the connection points. Connections should not be made at points where the noise level is especially strong, such as the oscillator circuit GND. Improving the GND is also intended to prevent static electricity from causing a malfunction. Improving the GND suppresses any potential difference between the GND generated when current from static electricity flows into the board.

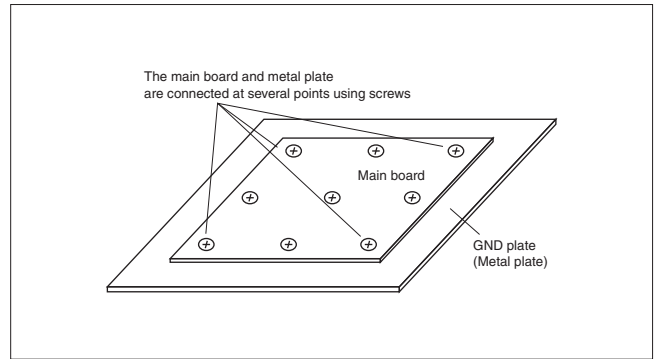

Installing EMI filters on Motor Control Lines

Noise generated by the motor is conducted to the main board and other cables via the motor cable and radiated. EMI filters are installed near the motor to suppress the noise.

In case that EMI filters cannot be installed near the motor, NFM21C series (Chip EMIFIL®) are installed on cable connections to the motor. However, the noise suppression effect may not be as much as that obtained by installing EMI filters near the motor.

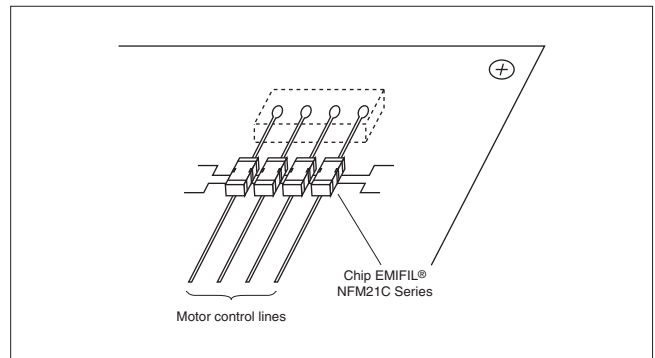

Installing EMI filters on the Parallel Interface

If noise is conducted to the printer cable, high levels of noise are radiated. Therefore, EMI filters are installed on the cable port (parallel interface) to suppress noise. Note that installing a filter with a large impedance value may sometimes hinder communication between the printer and personal computer.

Using a BLA31 series (Array type) decreases the mounting surface area.

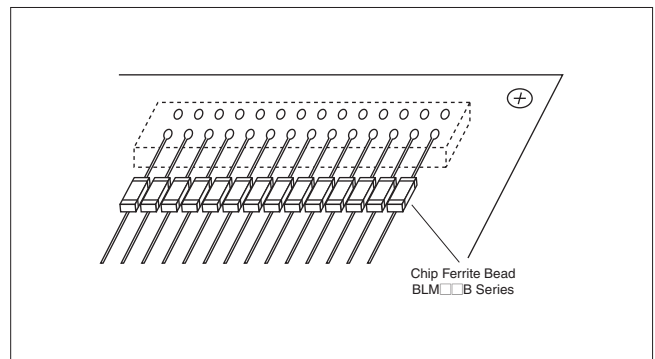

Installing EMI filters on the DC Power Supply Input and Lines

Noise is conducted from the DC power supply and GND lines to the switching power supply and radiated from the AC power supply cable. To suppress the noise, the BLM□□P series (Chip Ferrite Bead) is inserted onto each power supply line (including the GND line).

If the noise level is high, the NFM□□P series (Chip Solid EMIFIL® for DC power supply circuits) is installed in addition to the chip ferrite bead to achieve more noise suppression effect.

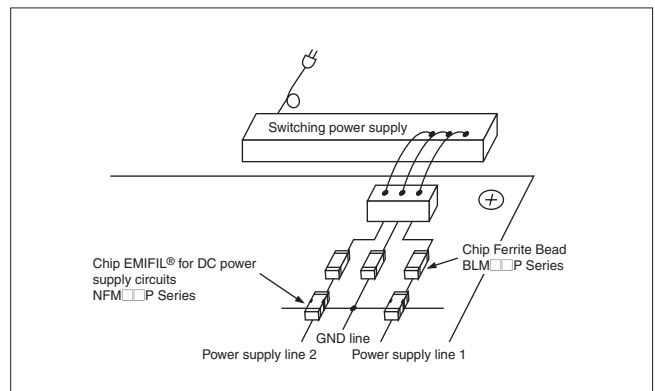

6 Example of Noise Suppression in Printers

Installing EMI filters on the Clock Line

Clock signals generate high frequency noise. Noise and signal frequencies may be close to each other. Therefore, an EMI filter with high and steep attenuation is used, such as the NFW31S series (Chip EMIFIL® for signal lines) or the BLM□□B series (Chip Ferrite Bead For high-speed signal lines).

Noise caused by transient currents is also generated on the power supply line. Therefore, a chip ferrite bead is installed, as well as a by-pass capacitor, to suppress noise on the power supply line.

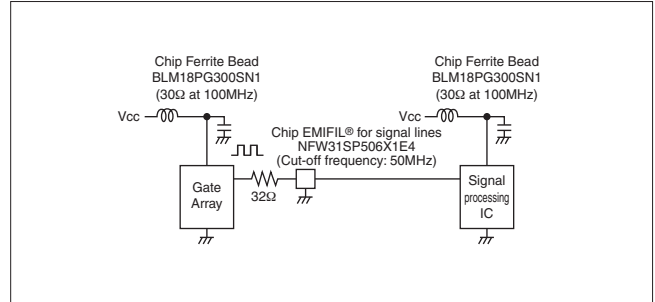

Example of effects produced when installing EMI filters on the Clock lines

Noise suppression effects produced when installing the EMI filter on the data clock lines.

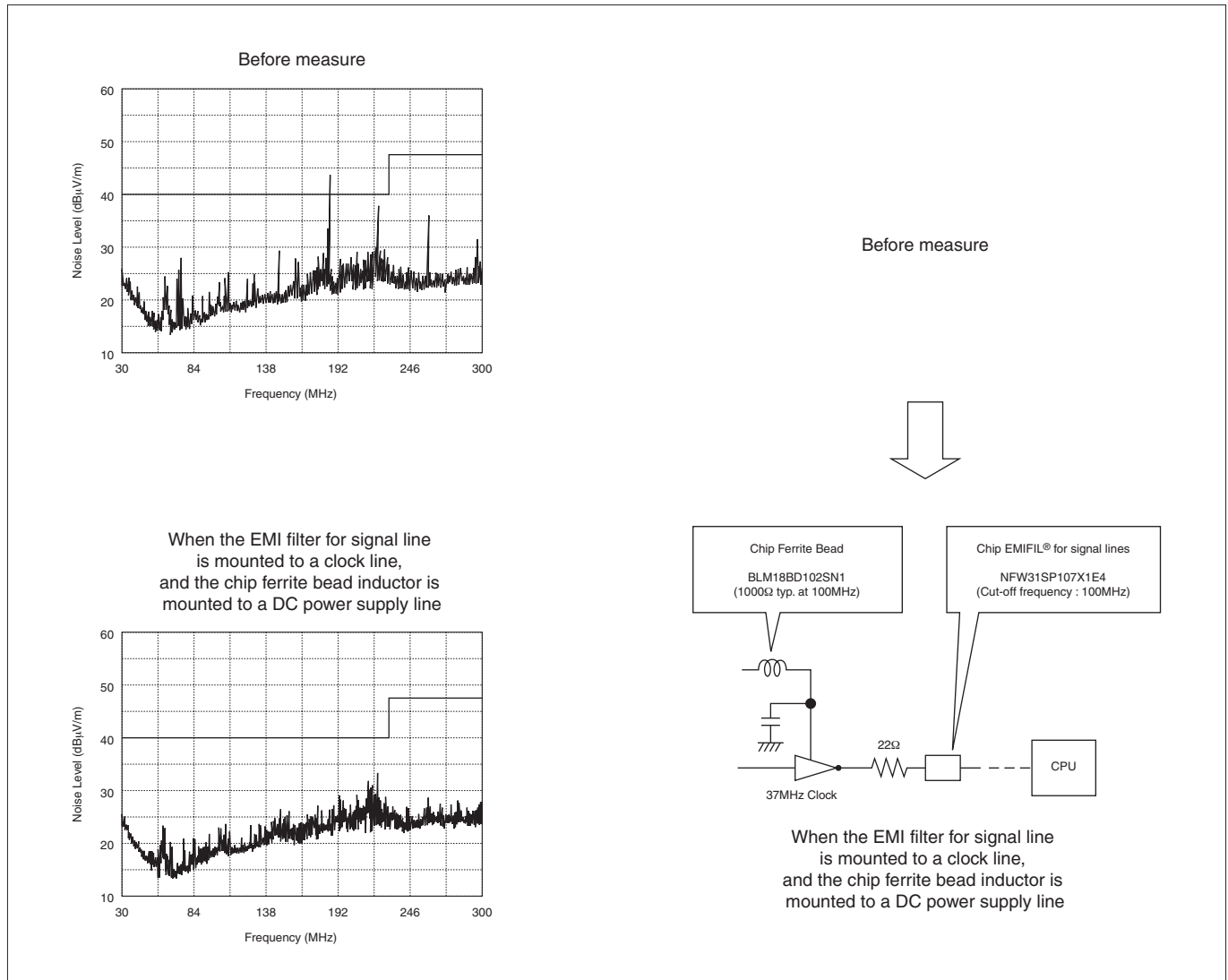

Example of Noise Suppression in Printers 6

Installing EMI filters on Bus Lines

Bus lines contain many lines that switch on and off simultaneously. This causes instantaneous large currents to flow into the GND and power supply lines through the data and address. Therefore, it is necessary to suppress the current flow on the signal lines. The BLM series (Chip Ferrite Bead) is generally used for this purpose. On the control bus line, especially at high operating speeds, the BLM□□B series (Chip Ferrite Bead for high-speed signal lines that features a steep impedance rising) is used. On bus lines with high-level noise, the NFM21G series (Chip EMIFIL[®]) is sometimes used.

The radiation spectrum of noise generated from bus lines resembles that of noise generated from the motor. It is important to check which of the motor or bus lines is the source of the noise and then install EMI filters.

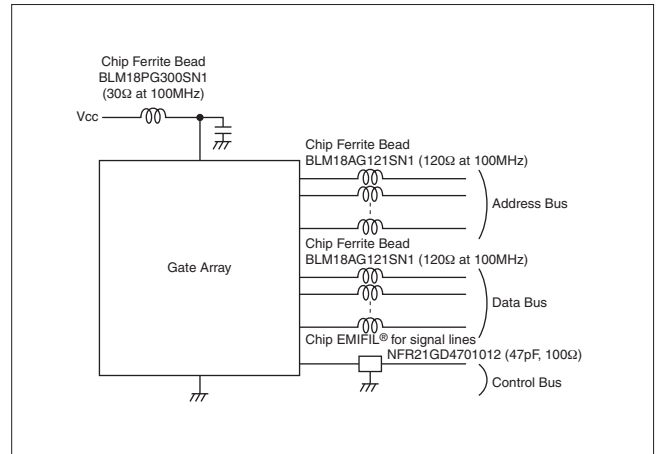

7 Example of Noise Suppression in Fax Machines

Noise Emission Status :

Digital noise generated from the main board of the facsimile machine is conducted to the handset cable, sensor signal input cable, and power supply cable.

The noise is then radiated using the cables as antennas.

With a facsimile machine, the main board is not shielded by a case or similar protection. Therefore, it is important to decrease the noise level from the board itself.

Since many kinds of cables are connected to the board, an EMI filter is installed on each cable.

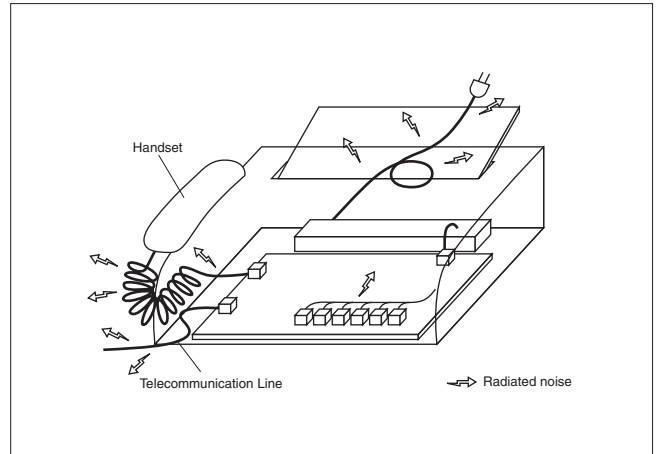

Example of Noise Suppression in Fax Machines 7

Noise Suppression Content in Fax Machines

The example above is a noise suppression model of a fax machine. As shown, there are many cables inside the facsimile which are notorious for generating EMI noise. In most cases, the cables are placed close to the main board. In this condition, the cables are coupled to the main board, causing the noise from the main board to be

emitted through the cable like an antenna. It is necessary to install EMI filters on the cable ports in addition to improving GND connections. It is also necessary to install EMI filters on the main board's digital circuits.

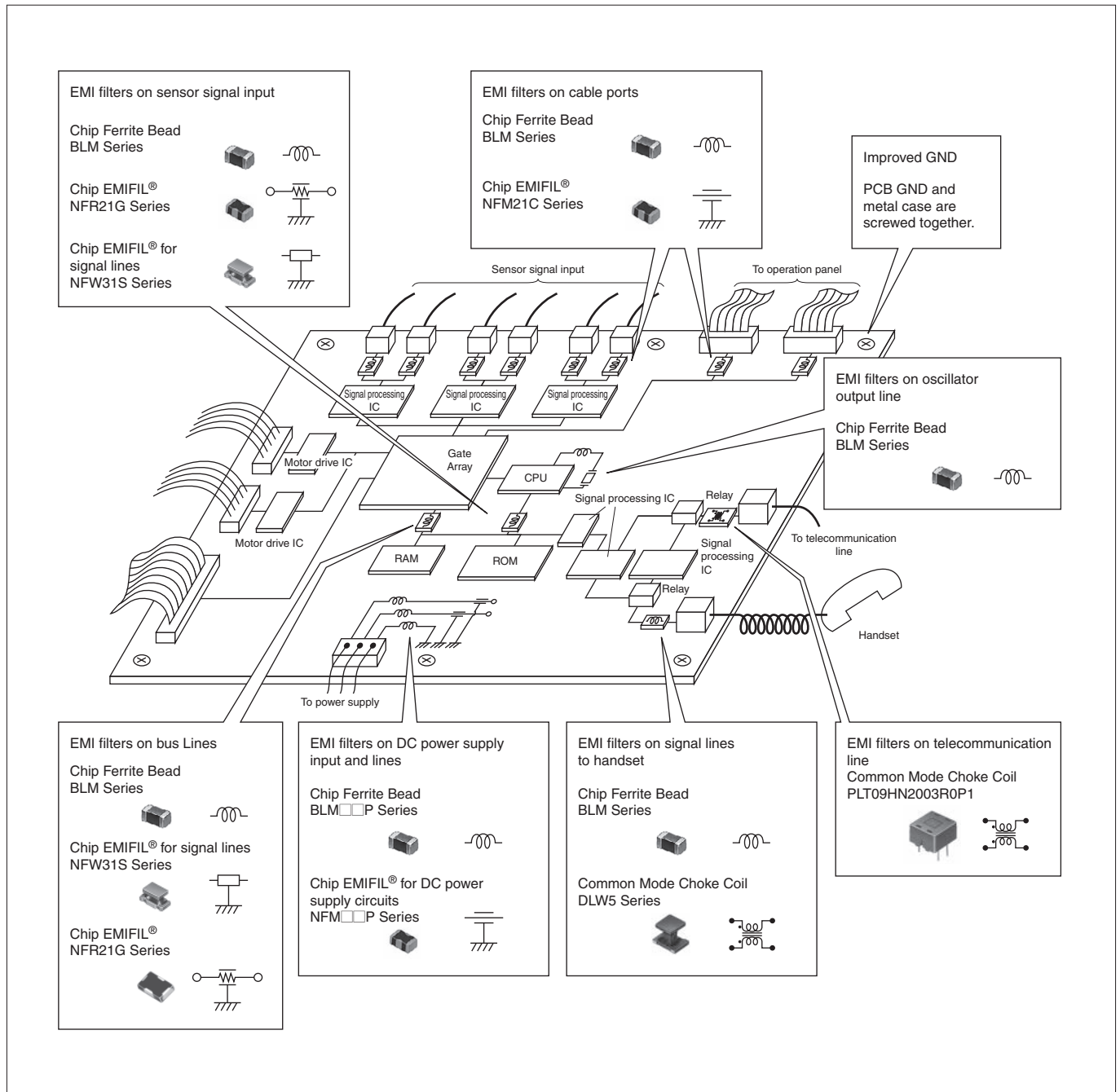

7 Example of Noise Suppression in Fax Machines

Installing EMI filters on Interface Cable Ports

When noise is conducted to the cable, strong noise is radiated from the cable. Therefore, the BLM series (Chip Ferrite Bead) is installed on the cable connection. Since sensor input signals for detecting the presence or absence of paper are of a low speed and temporary, an EMI filter whose impedance value is as large as possible should be used.

In case that the noise level is high, a capacitor chip EMIFIL® NFM series is used additionally to achieve more noise suppression effect.

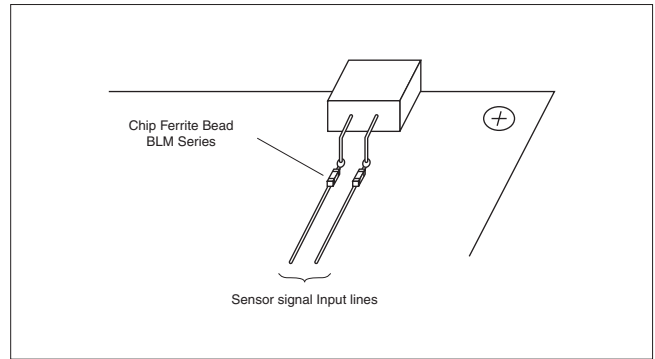

Installing EMI filters on the DC Power Supply Input and Lines

Noise is conducted from the DC power supply and GND lines to the switching power supply and radiated out using the AC power supply cable as an antenna. To suppress the noise, the BLM□□P series (Chip Ferrite Bead) and NFM□□P series (Chip EMIFIL® for DC power supply circuits) are installed close to the power supply connector.

A filter whose rated current is sufficiently larger than the power supply current should be selected.

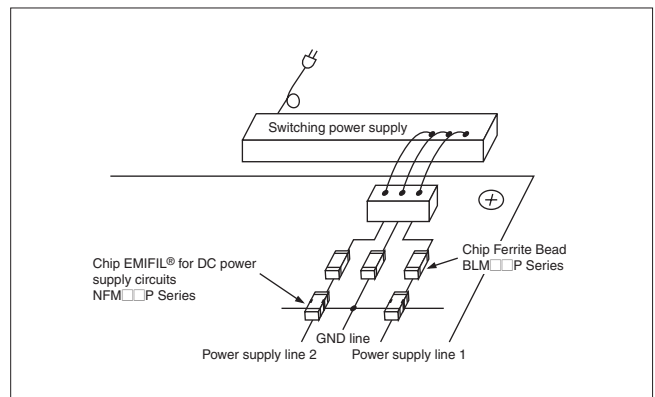

Installing EMI filters on Signal Lines to the Handset

Noise from the digital circuit is conducted to the handset cable and radiated from the cable.

Since the noise is common mode noise, the BLM series (Chip Ferrite Bead) or DLW5BS/AH series (Common Mode Choke Coil) is installed on all four lines to suppress the noise.

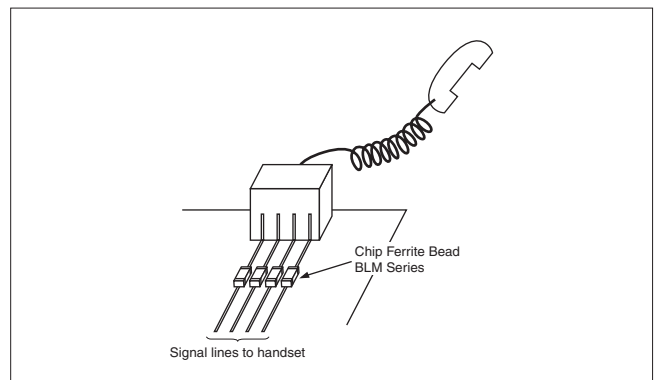

Installing EMI filters on the Clock Line

Clock signals contain noise covering the high frequency range, and in some cases, the clock signal frequency is close to the noise frequency. Therefore, an EMI filter that effectively eliminates noise in high frequency range and provides sharp cutoff, the NFW31S series EMIFIL® for signal lines and the BLM□□B series chip ferrite beads for high-speed signal lines, should be used. In combination with a resistor, the NFW31S series EMIFIL® can suppress overshoot and undershoot in the signal waveform, providing further improved noise suppressing effect.

Because power supply lines, as well as signal lines, conduct a transient current that causes noise emission, the BLM□□P series chip ferrite bead together with a bypass capacitor should be mounted to suppress noise conduction through the power supply lines.

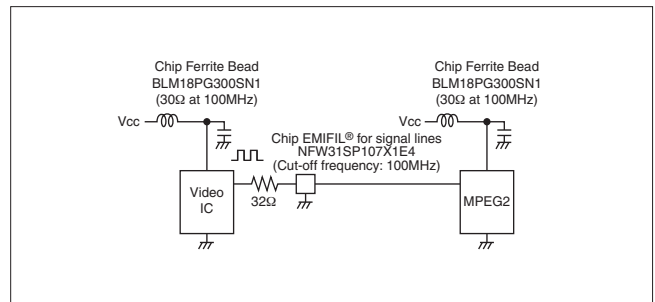

Example of Noise Suppression in Fax Machines 7

Example of effects produced when installing EMI filters on the Clock lines

Noise suppression effects produced when installing the EMI filter on the data clock lines.

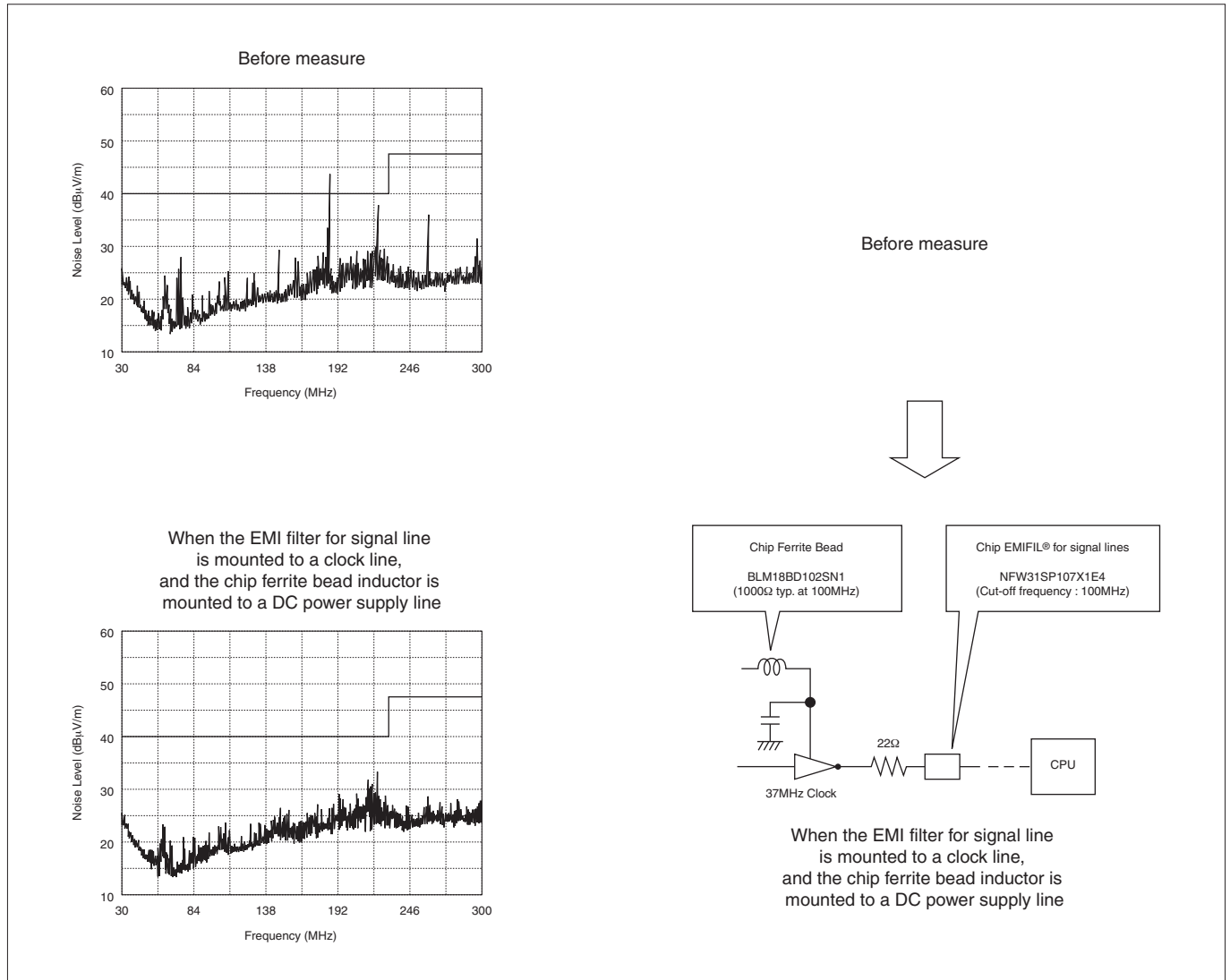

Installing EMI filters on Bus Lines

The Data and Address bus contain many lines that switch on and off simultaneously. This constant switching causes instantaneous large currents to flow through the GND and power supply lines resulting in unwanted noise. Therefore, it is necessary to suppress the current flow on the signal line. The BLM series (Chip Ferrite Bead) is generally used for this purpose. On the control bus line, especially at high operating speeds, the BLM□□B series (Chip Ferrite Bead for high-speed signal lines that features a steep impedance rising) is used. On bus lines with high-level noise, the NFR21G series (Chip EMIFIL®) may be effective. The radiation spectrum of noise generated from bus lines resembles that of noise generated from the motor. It is important to check which of the motor or bus lines is the source of the noise and then install EMI filters.

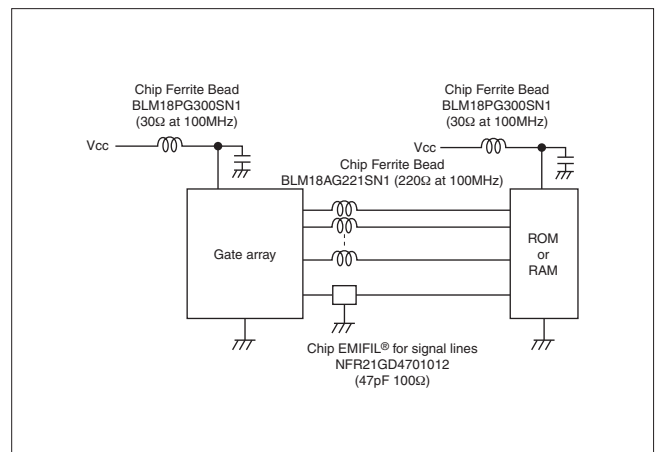

8 Example of Noise Suppression for Car Navigators

Noise Emission Status :

Noise from a car navigator radiates from the interface cable. Noise also radiates from the connector port openings in the metal case.

As car navigation system is located near car radio/TV, which is interfered by noise easily. The noise emission from the car navigation system should be suppressed much lower than regulation level by CISPR etc.

It is possible for the system to have function error/damage by strong noise from igniter.

Therefore, car navigation system should have noise suppression and noise protection.

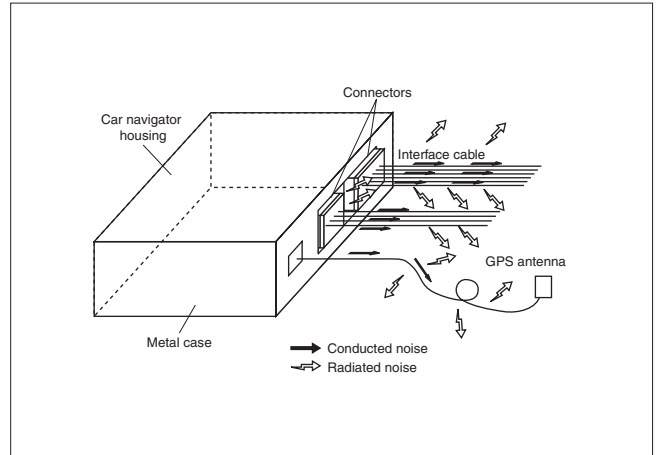

Example of Noise Suppression for Car Navigators 8

Noise Suppression Content in Car Navigators

The car navigator is shielded with a metal case to prevent noise radiation from the body, as well as noise entering into the system. EMI filters are installed on all lines of each interface cable to suppress noise conduction through the cable.

The noise suppression effects obtained by a capacitor type EMI filter installed in the cable connector port varies depending on the GND condition. Therefore, it is

necessary to pay much attention to the GND condition. Improve the GND connection between the PCB and metal case, and design the circuitry to minimize the impedance at high frequencies between the metal case and the GND of the capacitor type EMI filter.

Noise radiated from the car navigator can be most effectively suppressed by also installing EMI filters on the clock line, bus lines, and power supply line.

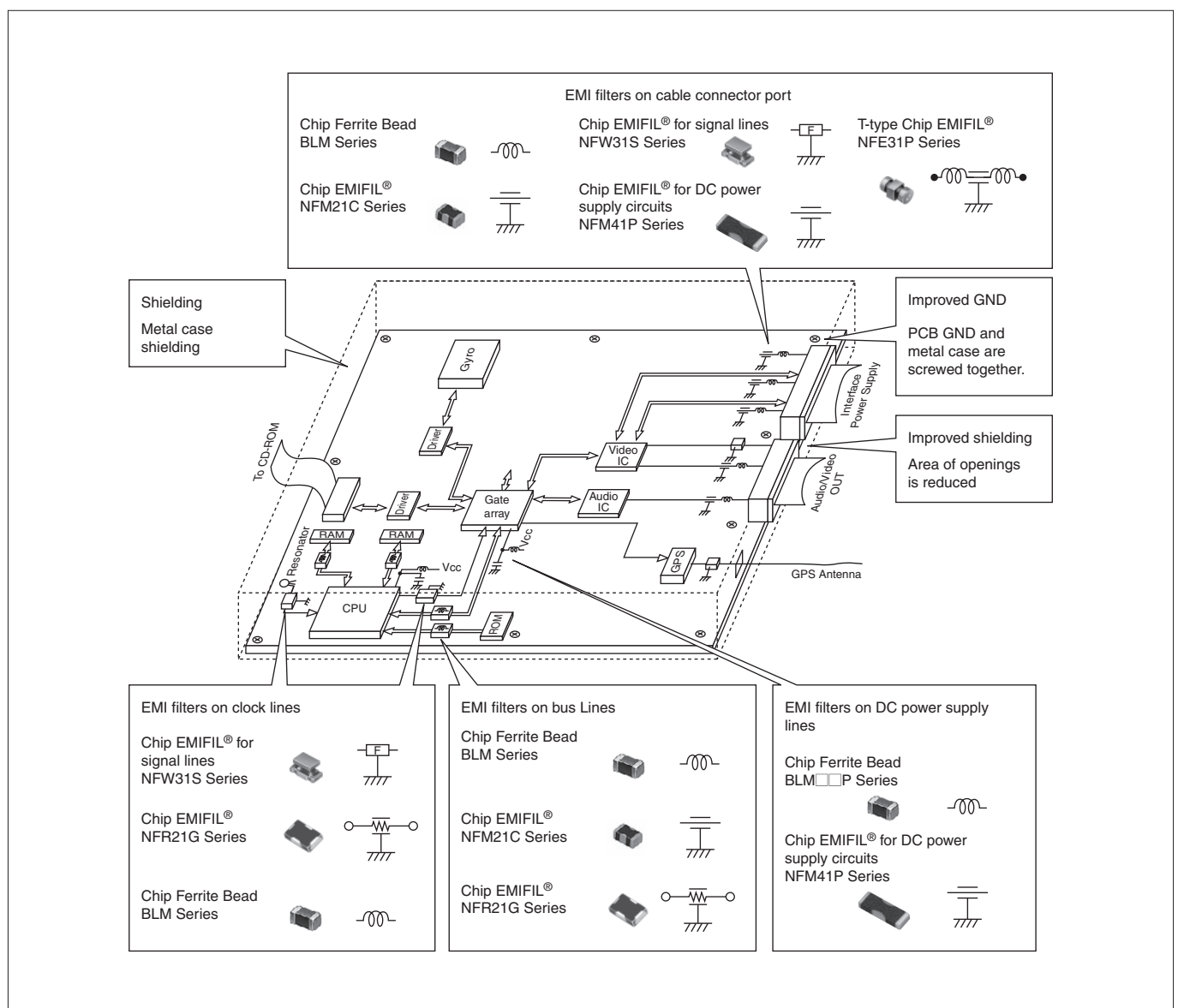

8 Example of Noise Suppression for Car Navigators

Improving the Shielding

Increasing the size of the opening in the metal case causes the shielding effect to decrease. As the opening gets larger, the shielding effect decreases. Large openings should be divided into multiple smaller openings to decrease the length of each opening, making each opening as small as possible.

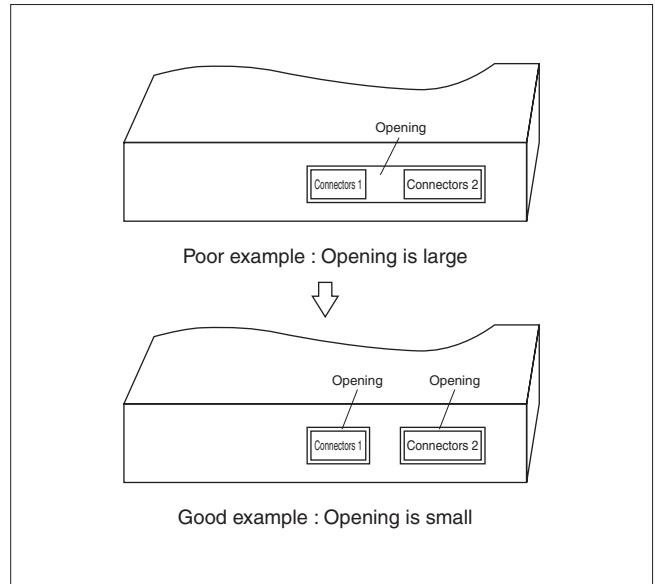

Installing EMI filters on Interface Cable Ports

For noise suppression in a cable connector, a combination of the NFM series chip EMIFIL® and the BLM series chip ferrite bead provides an enhanced noise suppressing effect. To make full use of the chip EMIFIL®'s noise suppressing effect, reduce the high frequency impedance between the filter GND and the shield case, and intensify the GND condition by screw-mounting the PCB GND to the shield case and connecting them with fingers, and by adding through holes for the filter GND.

If the GND pattern is distant from a connector, noise conduction occurs, resulting in noise emission from a cable. To prevent this problem, mount the filters near the connector terminals.

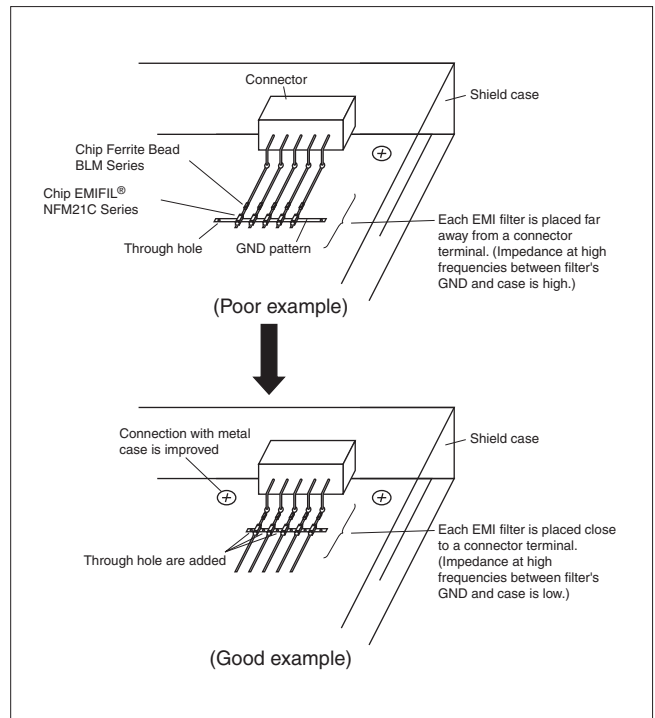

Example of Noise Suppression for Car Navigators 8

Example of effects produced when installing EMI filters on Interface Cable Ports

Noise suppression effects produced when installing the EMI filter on interface cable port.

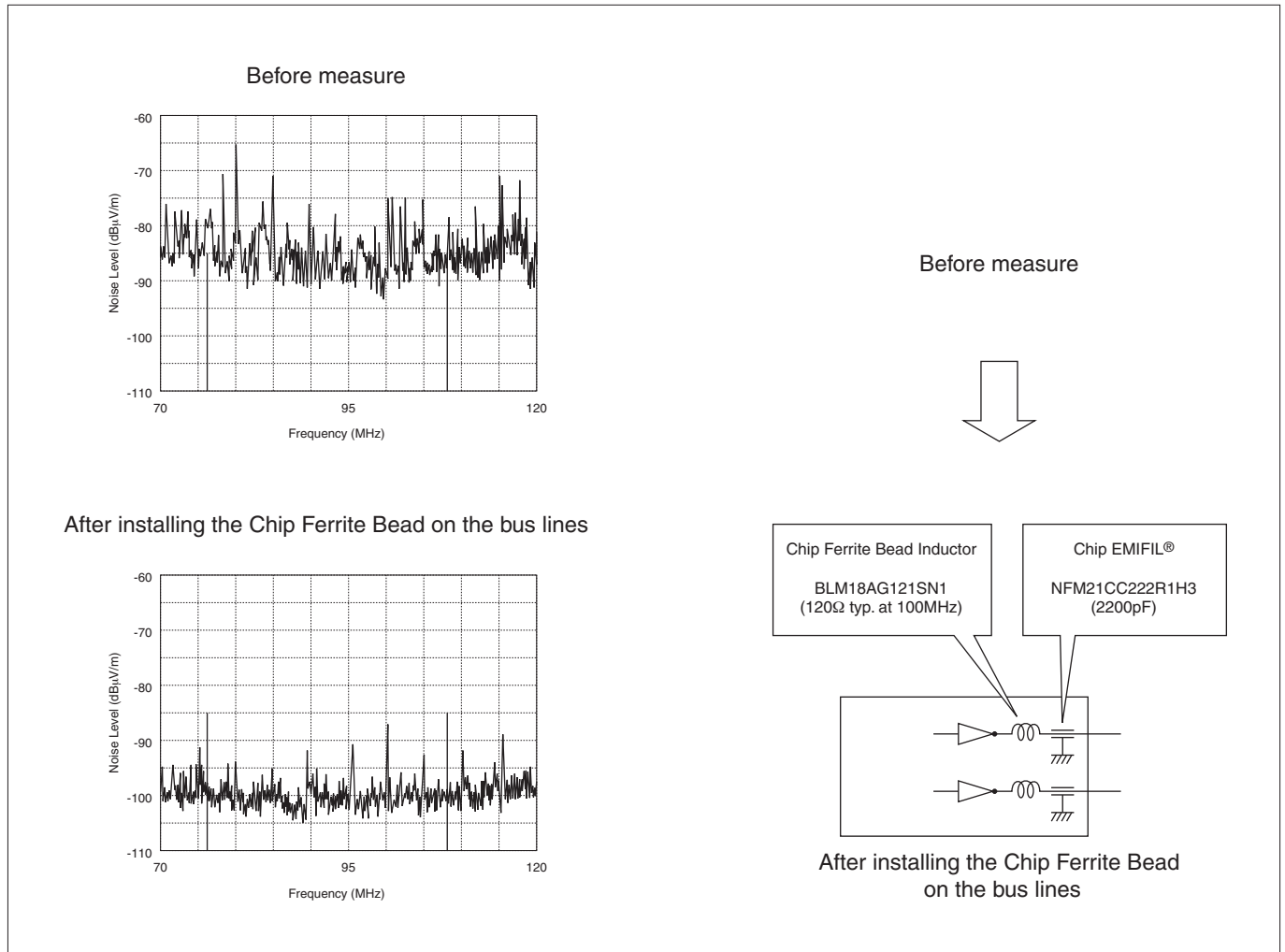

8 Example of Noise Suppression for Car Navigators

Installing EMI filters on the Clock Lines

High frequency clock signals generate high frequency noise. Noise and signal frequencies may be close to each other. Therefore, an EMI filter with high and steep attenuation is used, such as the NFW31S series (Chip EMIFIL® for signal lines) or the BLM□□B series (Chip Ferrite Bead for high-speed signal lines).

Noise caused by transient currents is also generated on the power supply line. Therefore, a chip ferrite bead is installed, as well as a by-pass capacitor, to suppress noise on the power supply line.

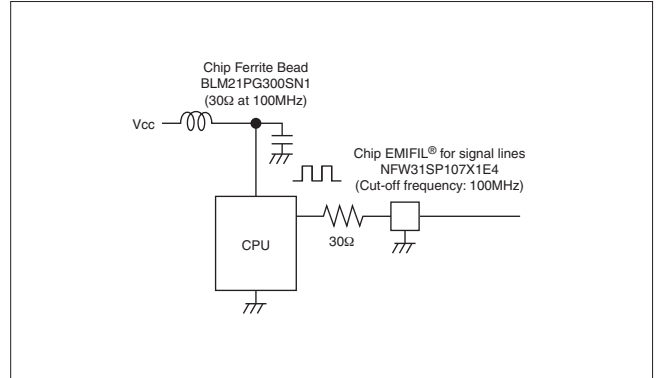

Installing EMI filters on Bus Lines

Bus lines contain many lines that switch on and off simultaneously. Especially on data and address bus lines, an instantaneous large current flows into the GND and power supply lines. Therefore, it is necessary to suppress the current flow on the signal lines. The BLM Series (Chip Ferrite Bead) is generally used for this purpose.

On the control bus line, especially at high operating speeds, the BLM□□B series (Chip Ferrite Bead) is used, featuring a sharp impedance rise at the specified frequency. For high noise levels, in some cases NFW31S series (Chip EMIFIL® for signal lines) is used.

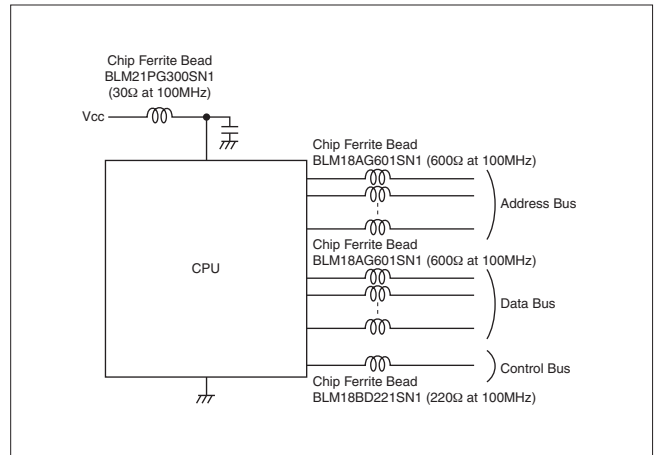

9 Example of Noise Suppression in AC Power Supplies

Noise Emission Status for Switching Power Supplies

In switching power supplies, noise is generated by the switching. This noise is conducted to the AC power supply cable. The cause of this noise does not meet as Mains Terminal Interference Voltage. Therefore, noise suppression is required for switching power supplies.

■ Noise from Switching Power Supplies

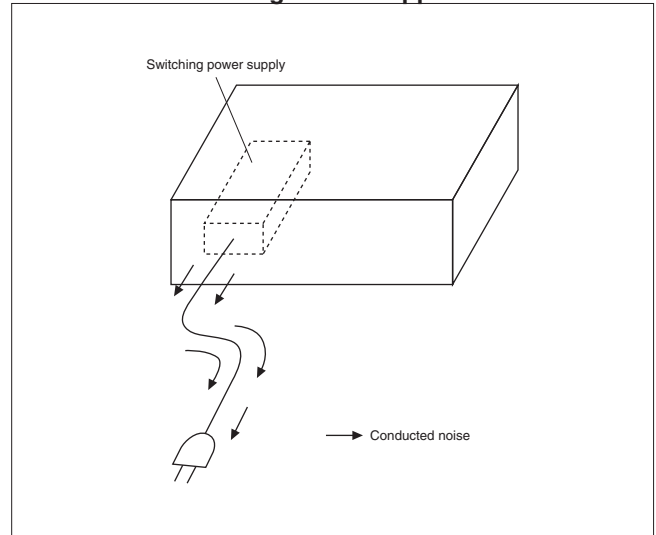

■ Example of Measured Noise in Switching Power Supplies

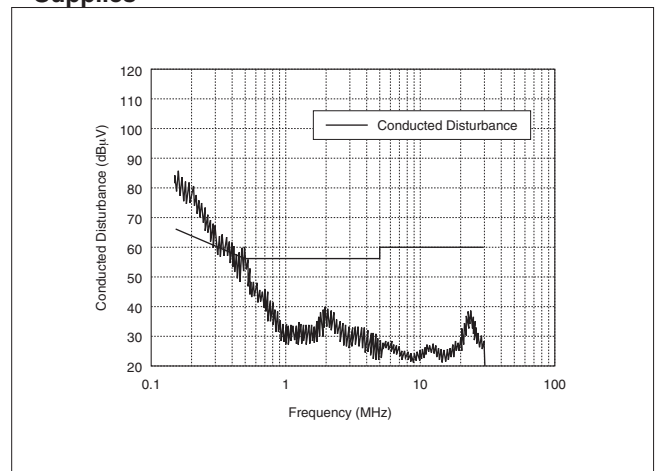

9 Example of Noise Suppression in AC Power Supplies

Noise Suppression Model for Ordinary Switching Power Supplies

In switching power supplies, noise filters are installed as shown below to suppress noise conducting to the AC power supply cable. The capacitors are used as a bypass for noise, and the coils suppress noise conduction to the cable by increasing line impedance.

■ Noise Suppression model for Switching Power Supplies

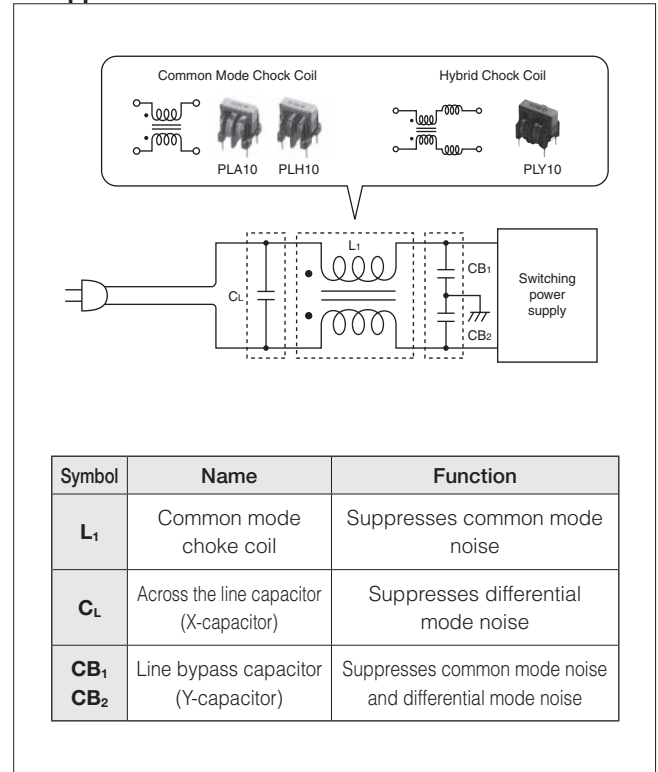

Example of Noise Suppression in AC Power Supplies **9**

Differential Mode Noise and Common Mode Noise

Noise is classified into two types: differential mode noise and common mode noise.

Differential mode noise is conducted on the two power supply lines in opposite directions to each other, as shown in Fig. (a).

Common mode noise is conducted on all lines in the same direction, as shown in Fig. (b).

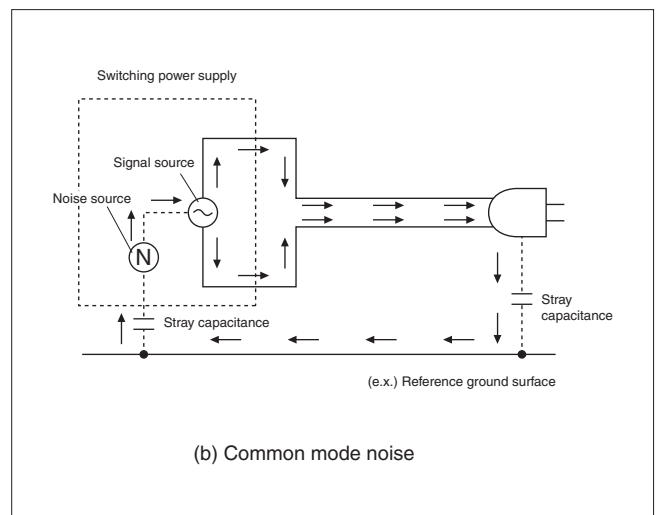
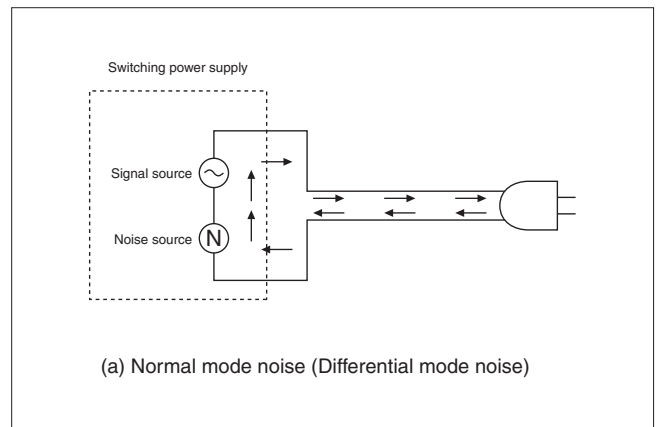
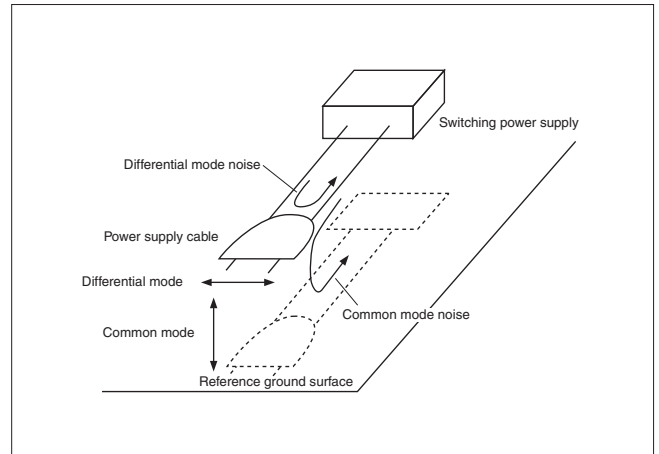

9 Example of Noise Suppression in AC Power Supplies

Functions of Respective Noise Filters

The figures above show examples of the functions of respective noise filters used in a switching power supply. To confirm these functions, changes in the Mains Terminal Interference Voltage are broken down into differential mode and common mode noise.

Figure (a) shows data obtained when no noise filter is used. This figure reveals that both the differential mode and common mode noise are high. Figure (b) shows data obtained when an X-capacitor is used. This figure reveals that the differential mode noise is decreased.

Figure (c) shows data obtained when both an X-capacitor and Y-capacitor are used. This figure reveals that both the common mode and differential mode noise are decreased. Figure (d) shows data obtained when an X-capacitor, Y-capacitor, and common mode choke coil are all used. This figure reveals that the differential mode noise is further decreased as well as the common mode one. This is because an actual common mode choke coil contains a certain amount of differential mode inductance.

Examples of confirming the Functions of Respective Noise Filters

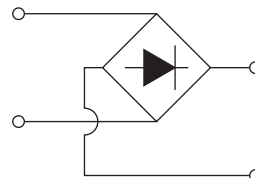
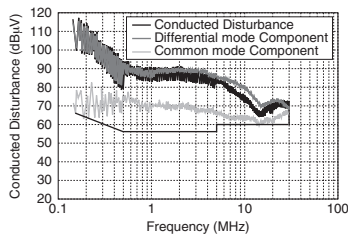

(a) No filter used

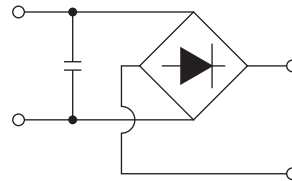
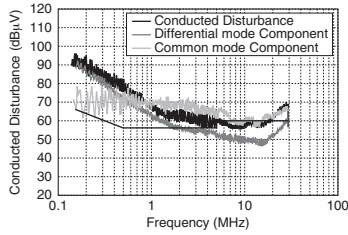

(b) X-capacitor used

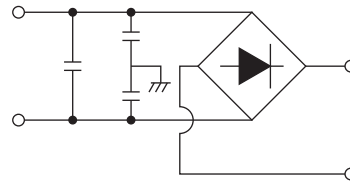
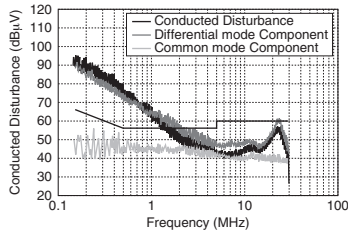

(c) Both X-and Y-capacitor used

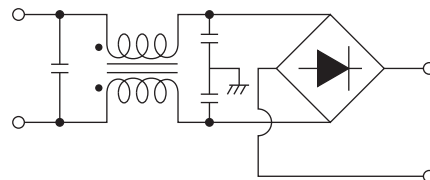
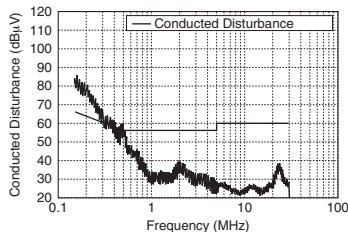

(d) X-capacitor, Y-capacitor, and common mode choke coil all used

Example of Noise Suppression in AC Power Supplies **9**

Noise Tendencies in Switching Power Supplies

Newer switching power supplies tend to have a high switching frequency that generates high levels of noise. Noise is especially strong in the several hundred kHz frequency range, close to the switching frequency. The figure below shows an example of measured Mains Terminal Interference Voltage. In this example, noise of 500kHz or less frequency is strongly generated. When this noise is broken down into common mode and differential mode components, it is found that the noise consists mainly of differential mode components. Newer switching power supplies tend to strongly generate low frequency differential mode noise. Therefore, more effective methods of suppressing differential mode noise are required.

■ Example of Resolving Noise into Differential Mode and Common Mode Components

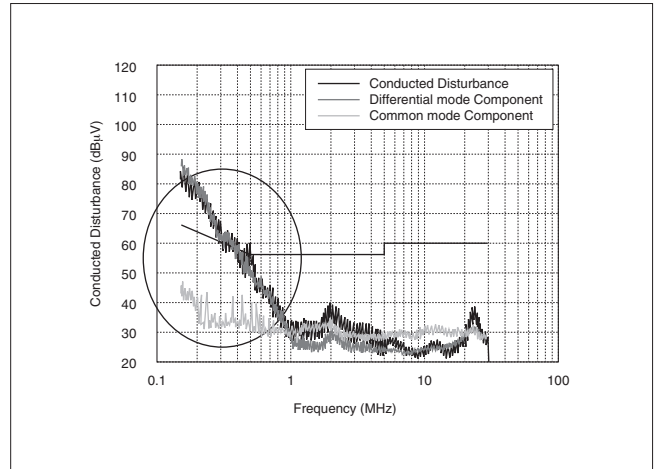

9 Example of Noise Suppression in AC Power Supplies

Examples of Suppression against Strong Differential Mode Noise

The figures below show examples of noise suppression in inverter power supplies for lighting equipment. Since low frequency differential mode noise is high, noise filters are installed as shown in figures (b), (c), and (d). Differential mode inductance is increased by adding more differential mode choke coils in figure (b), adding another common mode choke coil in figure (c), and increasing the size of the common mode choke coil in figure (d). The reason why a common mode choke coil contains differential mode inductance is that magnetic flux caused by differential mode current does not entirely cancel out because it produces leakage flux. One would think that a capacitor with a larger constant should be used for suppression against differential mode

noise. However, increasing the X-capacitor's capacitance causes a problem of increased reactive current. In addition, increasing the Y-capacitor's capacitance causes a problem of increased leakage current. For these reasons, a capacitor with very large capacitance cannot be used. Therefore, when differential mode noise is strong, it is necessary to increase differential mode inductance as shown in figures (b), (c), and (d). However, using the suppression methods shown above causes problems with the increased number of components, with the mounting area, and with the cost. To solve these problems, a choke coil with unchanged common mode inductance and increased differential mode inductance is in demand.

Examples of Differential Mode Noise Suppression by Adding Choke Coils or Increasing Its Size

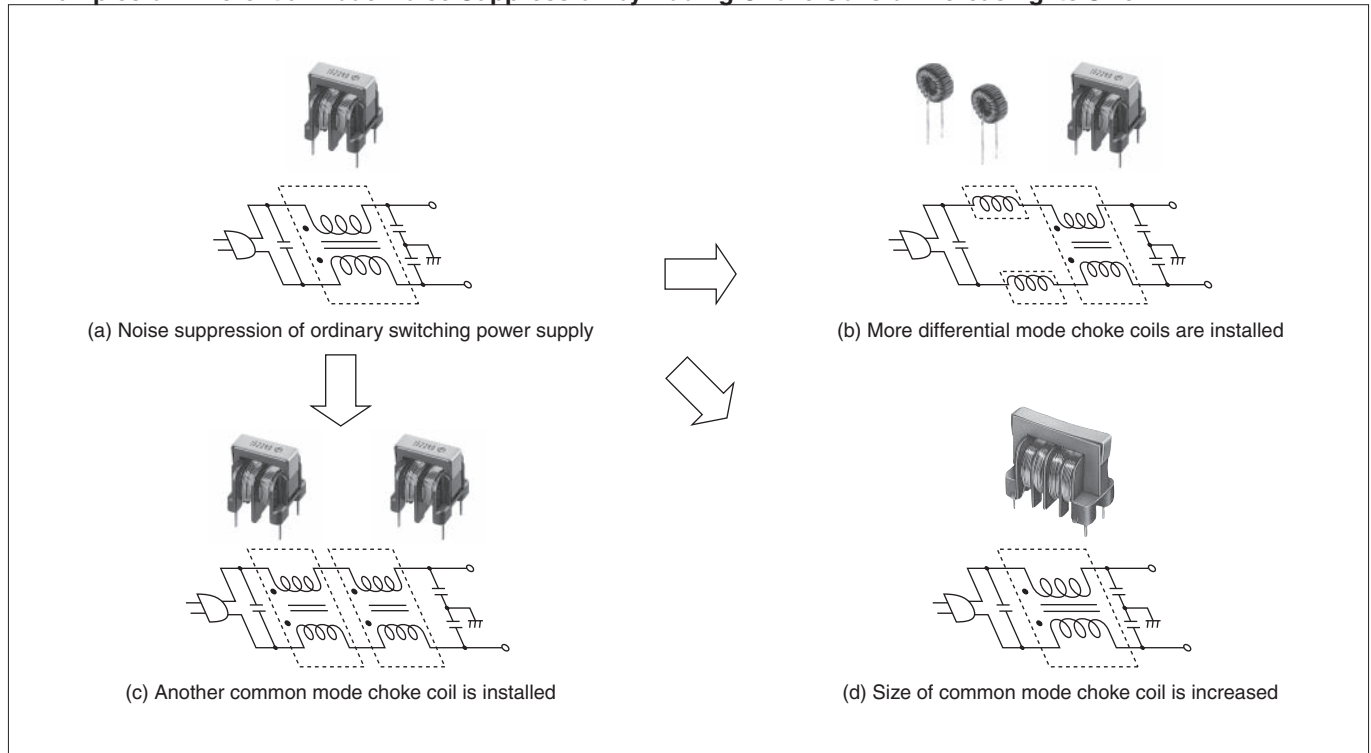

Example of Noise Suppression in AC Power Supplies **9**

Reasons Why Common Mode Choke Coils Contain Mode Inductance

With an ideal common mode choke coil, magnetic flux caused by common mode current is accumulated inside the ferrite core. Therefore, the common mode choke coil works as an inductor against common mode current. On the other hand, magnetic flux caused by differential mode current cancels out. Therefore, a common mode choke coil does not affect differential mode current. However, since an actual common choke coil produces leakage flux, magnetic flux caused by differential mode current does not entirely cancel out. In other words, an actual common mode choke coil contains differential mode inductance as well as common mode inductance.

■ Ideal Common Mode Choke Coil

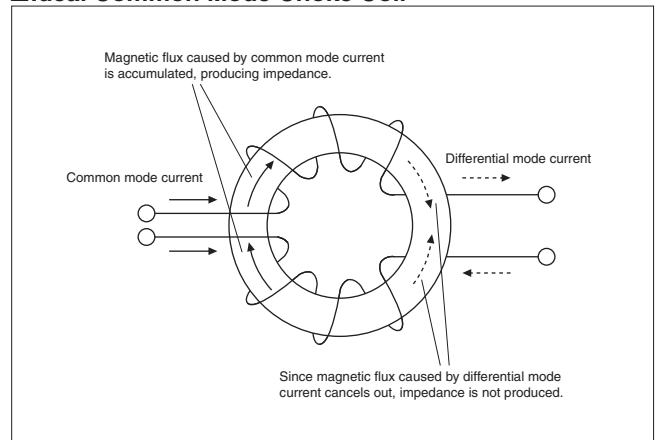

■ Actual Common Mode Choke Coil

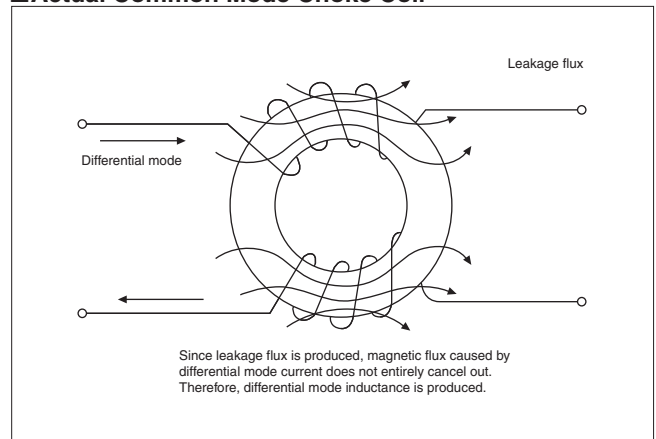

9 Example of Noise Suppression in AC Power Supplies

Effective Suppression Methods against Differential Mode Noise using Hybrid Choke Coils

The hybrid choke coil is available as a common mode choke coil with increased differential mode inductance. The appearance and equivalent circuit for the PLY10 series hybrid choke coil are shown above. The devised structure allows the hybrid choke coils to have increased differential mode inductance. For example, the PLY10 series hybrid choke coil contains 3 to 5 times larger differential mode inductance as the previous common mode choke coil of the same size, while the hybrid choke coil contains common mode inductance equivalent to that of the previous common mode choke. In other words, differential mode noise can effectively be suppressed as well as common mode noise, simply by replacing the previously used common mode choke coil with the PLY10 series. This cuts the number of components and mounting area in half, compared to adding another differential mode choke coil or common mode choke coil on the circuit.

■PLY10 Series Hybrid Choke Coil

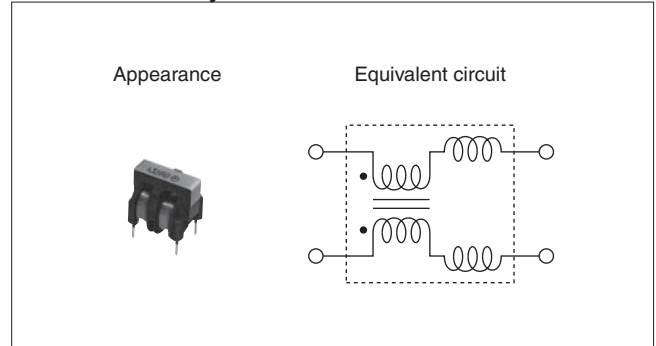

■Advantage of Using Hybrid Choke Coils for Noise Suppression

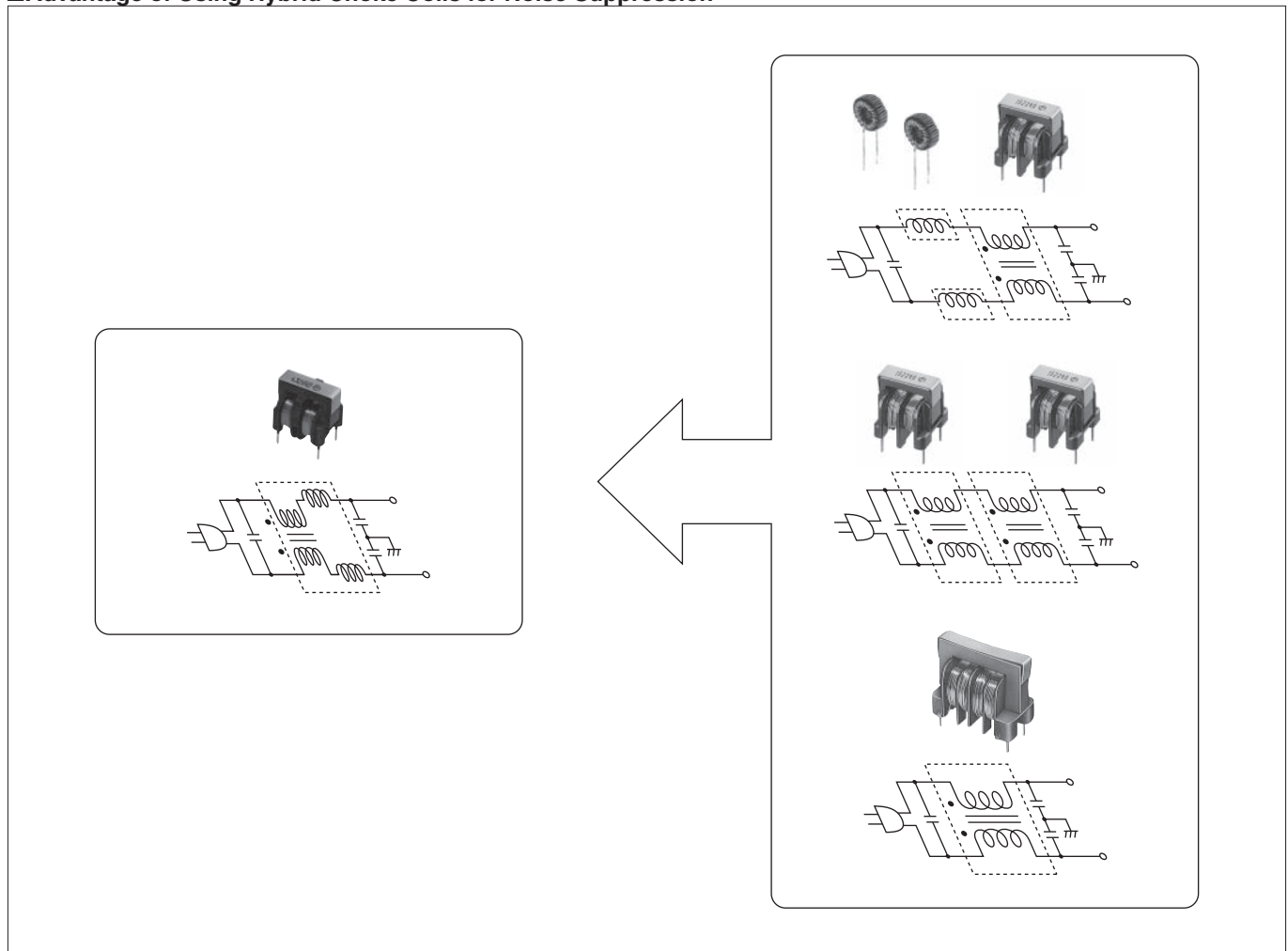

Example of Noise Suppression in AC Power Supplies **9**

Examples of Confirming the Effectiveness of Hybrid Choke Coils

An example to confirm the effects obtained by using the PLY10 series hybrid choke coil is shown above in Fig. 1. Compared with adding an additional differential mode choke coil, using the PLY10 series suppresses Mains Terminal Interference Voltage with a smaller circuit and decreases the mounting area. (Although this example uses lighting equipment as a suppression model, the same suppression methods can be used for switching power supplies.)

■Example of Using the PLY10 Series Hybrid Choke Coil

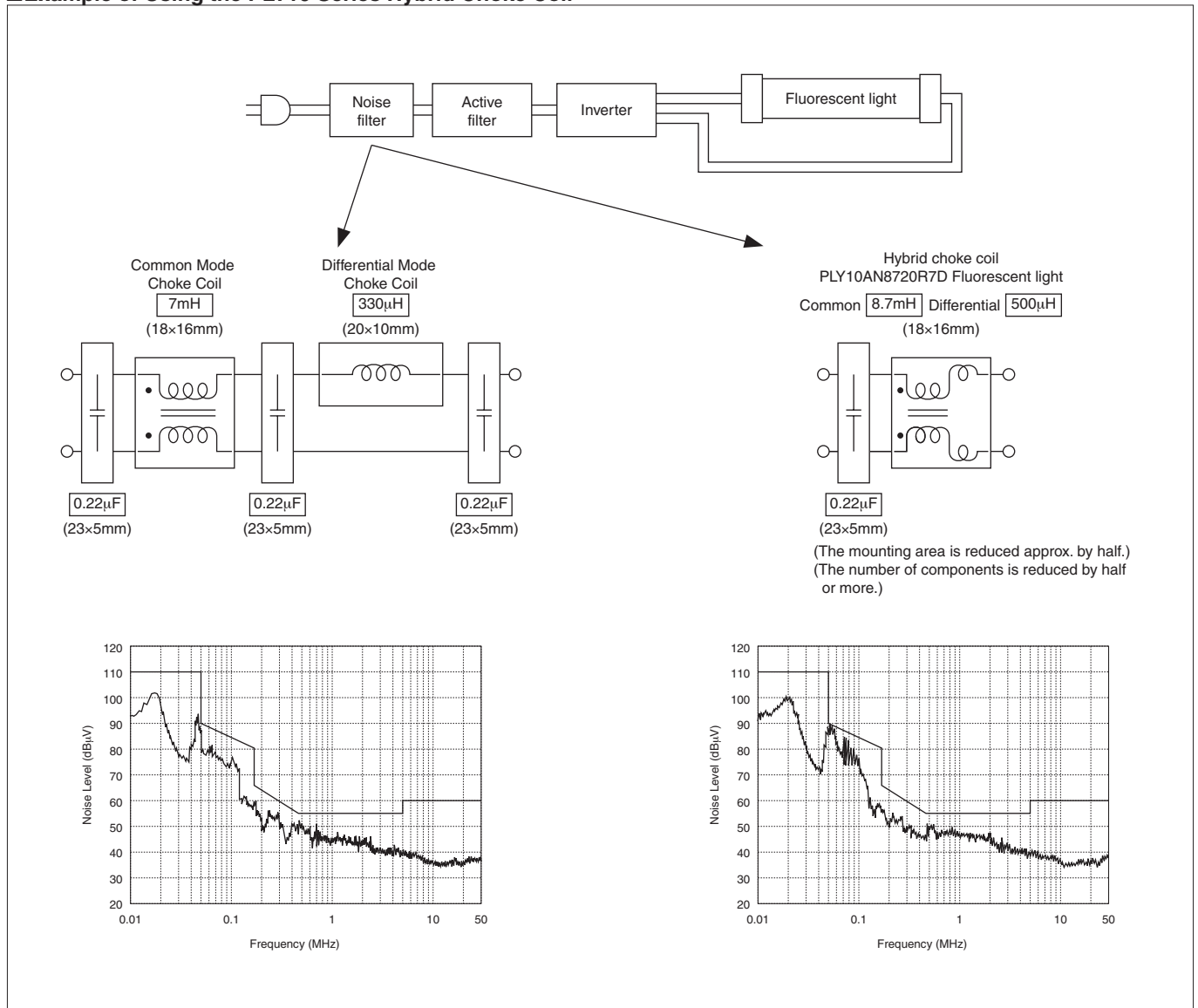

10 Example of Noise Suppression in Mobile Phones

Noise Emission Status :

When noise from the base band section flows into RF section, sensitivity suppression occurs, resulting in BER (Bit Error Rate) deterioration.

Mobile phone base band section, typically the base band IC, controls various signals such as voice signal and LCD signal. The base band IC is a significant noise source, because it operates at a high-speed and connects many data lines. If such noise flows into the RF section through the data line or power/GND line, sensitivity suppression occurs, resulting in BER (Bit Error Rate) deterioration.

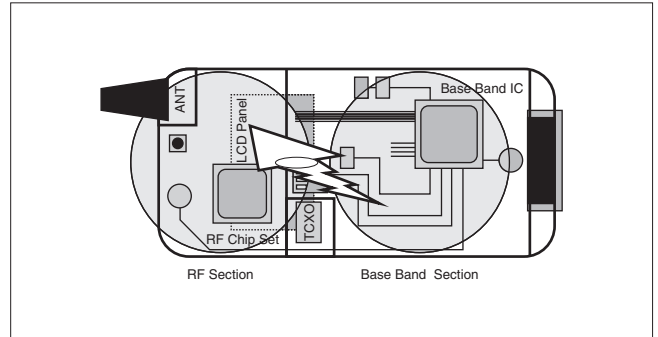

Example of Noise Suppression in Mobile Phones 10

Noise Suppression content in Mobile Phones

To improve BER (Bit Error Rate) deterioration, it is necessary to suppress noise conduction from the base band section to the RF section. For this purpose, the EMI filter should be mounted to the noise conduction route between the base band section and the RF section.

Recently, as the base band section's noise level has become higher, shielding the base band section is now also important.

The following pages provide detailed description on noise suppression models for the above five items.

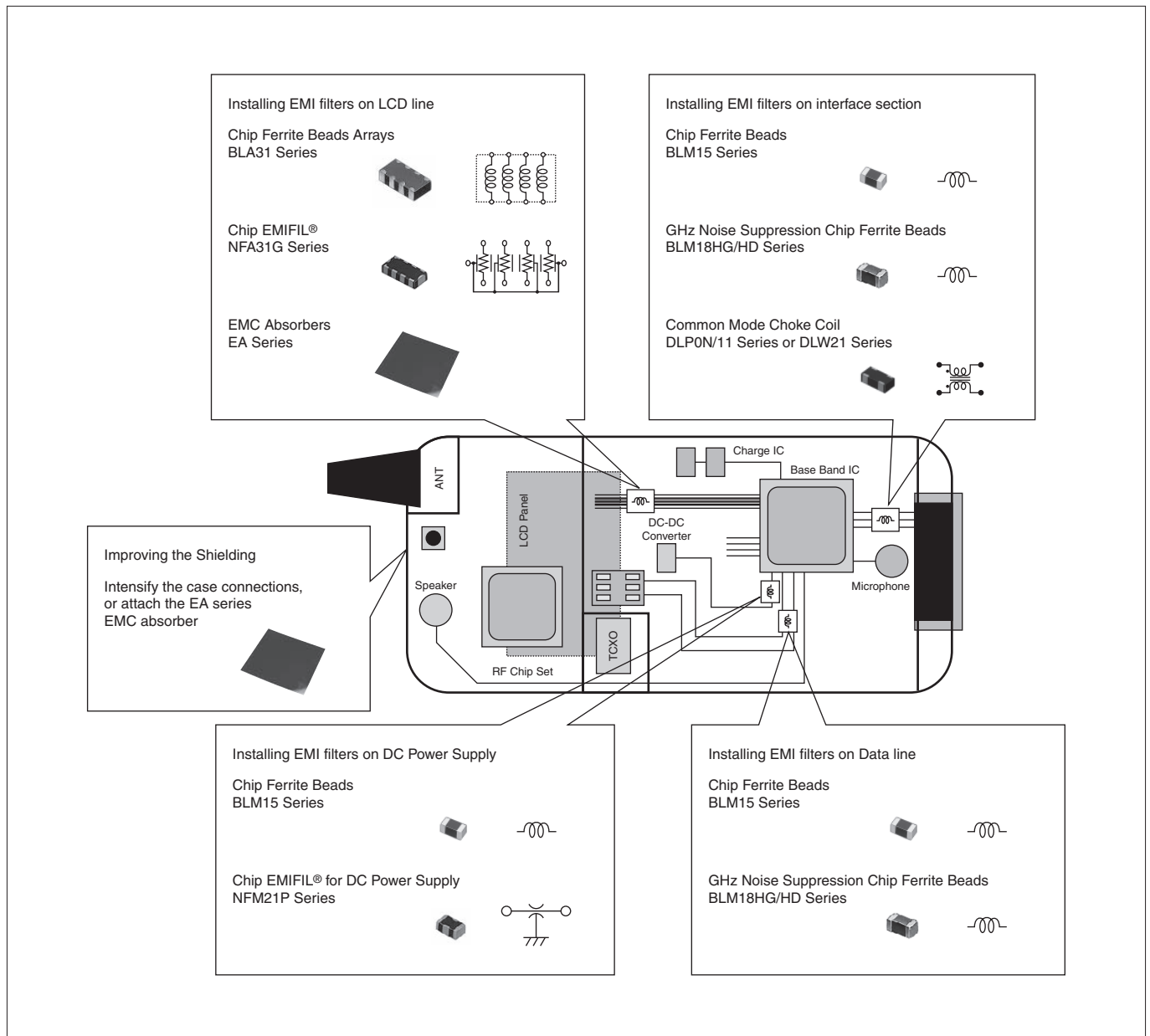

10 Example of Noise Suppression in Mobile Phones

Installing EMI filters on LCD line

Because LCD's data bus and address bus are comprised of many lines that simultaneously turn on or off, a large current flows into the power/CND line instantaneously. Therefore, it is necessary to take measures for suppressing the current flow into the signal line. Typically, the BLA31 series chip ferrite bead array, and the NFA31G series chip EMIFIL[®] with resistance can be used for this purpose. If these components cannot be inserted, the EA series EMC absorber should be attached to the flexible cable for the LCD, to suppress noise conduction through the flexible cable.

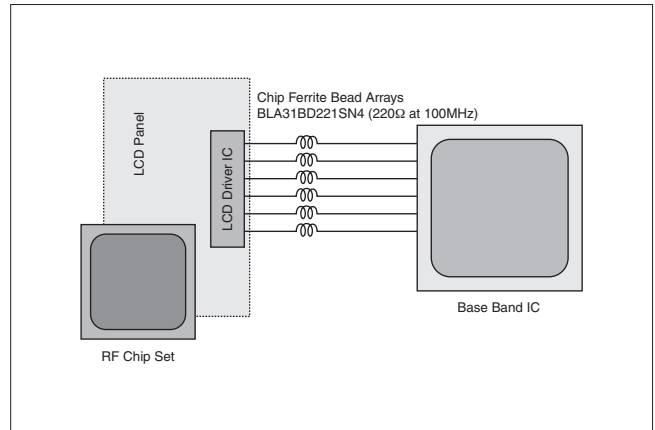

Installing EMI filters on DC Power Supply

To suppress noise conduction from the base band section to the RF section through a DC power supply line, the BLM15 series chip ferrite bead should be mounted to the DC power supply line. A combination of the ferrite bead and the NFM21P series chip EMIFIL[®] for DC power supply lines provides an enhanced noise suppressing effect. The NFM21 P series chip EMIFIL[®] is a three terminal capacitor, which provides better high frequency characteristics than a two terminal capacitor. When a bypass capacitor is comprised of several two terminal capacitors with different constants, they can be replaced with a single chip EMIFIL[®], which provides an advantage in mounting space.

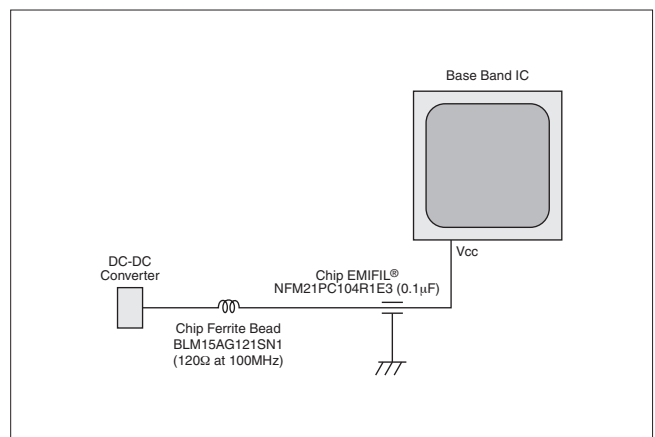

Installing EMI filters on Data Line

The base band section contains many data lines. As a typical example, a SIMM data line is described here. A chip ferrite bead BLM15AG601SN1 is mounted to the SIMM data line to suppress noise conduction. Since the SIMM data line operates at a relatively low speed, a chip ferrite bead with large impedance can be used. However, if a chip ferrite bead with large impedance is used for a high-speed data transmission line, it will adversely affect the transmission signal waveform, resulting in waveform deformation, rounding or operation failure. To prevent these problems, the BLM15BB/BD series ferrite bead for signal lines, which has little influence on the signal waveform, should be used for high-speed signal lines.

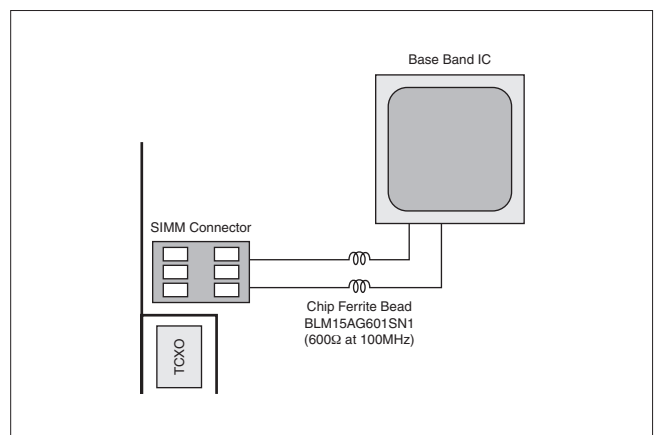

Example of Noise Suppression in Mobile Phones 10

Installing EMI filters on interface section

If noise flows through an interface cable, noise emitted from the cable is diffracted and flows into the antenna, causing BER deterioration. To suppress noise conduction through the interface cable, the BLM15 series chip ferrite bead should be mounted between the base band IC and the cable connector.

For mobile phones with high communication frequency (e.g. PDC1.5, DCS, PCS), using the DLP0N/11 or DLW21 series common mode choke coil, which provides high impedance in this frequency range, offers more excellent noise suppressing effect.

For noise suppression in interfaces, immunity test and transmission wave diffraction preventive measures are required. Therefore, it is necessary to select the optimum EMI filters according to the intended purpose and frequency band.

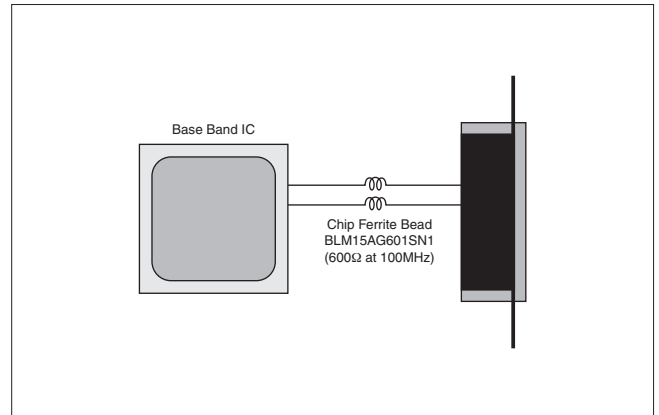

Improving the Shielding

Generally, the mobile phone resin case is shielded by conductive plating. As mobile phones have become more functional, the noise level from the base band section has been increased. Therefore, it is important to shield the base band section, as well as the RF section. Mobile phones should be designed to make the contact surface of the case as large as possible, and to reduce high frequency impedance.

Shielding the base band section partially with a metal case or attaching the EMC absorber to the shield contact surface can also intensify the shielding condition.

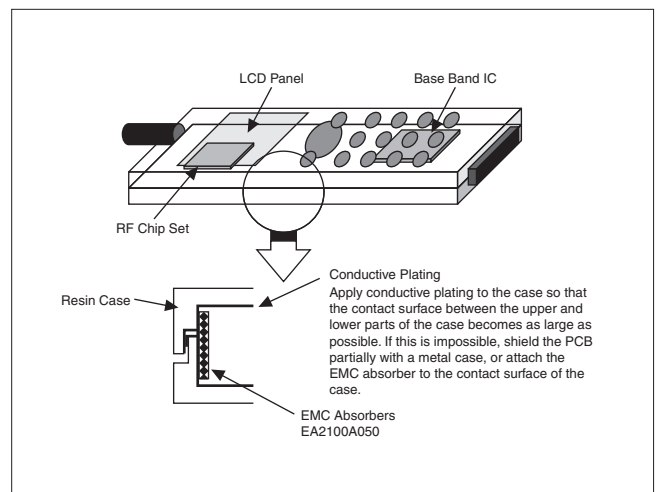

⚠Note:

1. Export Control

<For customers outside Japan>

No Murata products should be used or sold, through any channels, for use in the design, development, production, utilization, maintenance or operation of, or otherwise contribution to (1) any weapons (Weapons of Mass Destruction [nuclear, chemical or biological weapons or missiles] or conventional weapons) or (2) goods or systems specially designed or intended for military end-use or utilization by military end-users.

<For customers in Japan>

For products which are controlled items subject to the "Foreign Exchange and Foreign Trade Law" of Japan, the export license specified by the law is required for export.

2. Please contact our sales representatives or product engineers before using the products in this catalog for the applications listed below, which require especially high reliability for the prevention of defects which might directly damage a third party's life, body or property, or when one of our products is intended for use in applications other than those specified in this catalog.

- | | |
|-----------------------------|--|
| ① Aircraft equipment | ② Aerospace equipment |
| ③ Undersea equipment | ④ Power plant equipment |
| ⑤ Medical equipment | ⑥ Transportation equipment (vehicles, trains, ships, etc.) |
| ⑦ Traffic signal equipment | ⑧ Disaster prevention / crime prevention equipment |
| ⑨ Data-processing equipment | ⑩ Application of similar complexity and/or reliability requirements to the applications listed above |

3. Product specifications in this catalog are as of May 2012. They are subject to change or our products in it may be discontinued without advance notice.

Please check with our sales representatives or product engineers before ordering. If there are any questions, please contact our sales representatives or product engineers.

4. Please read rating and ⚠CAUTION (for storage, operating, rating, soldering, mounting and handling) in this catalog to prevent smoking and/or burning, etc.

5. This catalog has only typical specifications because there is no space for detailed specifications. Therefore, please review our product specifications or consult the approval sheet for product specifications before ordering.

6. Please note that unless otherwise specified, we shall assume no responsibility whatsoever for any conflict or dispute that may occur in connection with the effect of our and/or a third party's intellectual property rights and other related rights in consideration of your use of our products and/or information described or contained in our catalogs. In this connection, no representation shall be made to the effect that any third parties are authorized to use the rights mentioned above under licenses without our consent.

7. No ozone depleting substances (ODS) under the Montreal Protocol are used in our manufacturing process.

Head Office

1-10-1, Higashi Kotari, Nagaokakyo-shi, Kyoto 617-8555, Japan
Phone: 81-75-951-9111

International Division

3-29-12, Shibuya, Shibuya-ku, Tokyo 150-0002, Japan
Phone: 81-3-5469-6123 Fax: 81-3-5469-6155 E-mail: intl@murata.co.jp